

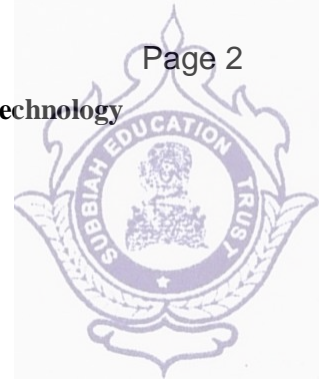

Department of Civil Engineering

**Regulation 2021
II Year – III Semester
CE3302/ Construction Materials and Technology**



UNIT-I

STONES - BRICKS - CONCRETE BLOCKS - LIME

MANUFACTURING PROCESS OF BRICKS

The process of manufacturing of bricks from clay involves preparation of clay, moulding and then drying and burning of bricks. The bricks are building materials which are generally available as rectangular blocks. The bricks do not require any dressing and brick laying is very simple compared to stone masonry.

Site selection for manufacturing of bricks

For the manufacturing of bricks, the site should be selected based on some important considerations such as:

- The ground should be of plain surface.
- The site should be connected with communicating roads for transporting materials etc.,
- Good brick earth should be easily available.
- The site should offer all facilities to the workers.

Manufacturing process of bricks

There are four different operations are involved in the process of manufacturing of bricks:

1. Preparation of clay
2. Moulding
3. Drying
4. Burning

1. Preparation of clay for brick manufacturing:

Preparation of clay for bricks manufacturing is done in six steps:

Un soiling of clay We need pure clay for the preparation of bricks. The top layer of soil may contain impurities, so the clay in top layer of soil about 200mm depth is thrown away. This is called unsoiling.

Digging After the removal of top layer, the clay is dug out from the ground and spread on the plain ground.

Cleaning In this stage, the clay is cleaned of stones, vegetable matter etc. if large quantity of particulate matter is present, then the clay is washed and screened. The lumps of clay are converted into powder with earth crushing rollers.

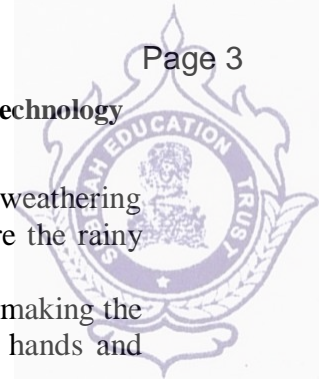

Weathering The cleaned clay is exposed to atmosphere for softening. The period of weathering may be 3 to 4 weeks or a full rainy season. Generally, the clay is dug out just before the rainy season for larger projects.

Blending If we want to add any ingredient to the clay, it is to be added in this stage by making the clay loose and spread the ingredient over it. Then take small portion of clay into the hands and tuning it up and down in vertical direction. This process is called blending of clay.

Tempering In this stage, water is added to clay and pressed or mixed. The pressing will be done by cattle or with feet of men for small scale projects, pug mill is used as grinder for large scale projects. So, the clay obtains the plastic nature and now it is suitable for moulding.



2. Moulding of clay for brick manufacturing

In the mouldings process, prepared clay is mould into brick shape (generally rectangular). This process can be done in two ways according to scale of project.

- Hand moulding (for small scale)
- Machine mouldings (for large scale)

Hand moulding of bricks

If manufacturing of bricks is on a small scale and manpower is also cheap then we can go for hand moulding. The moulds are in rectangular shape made of wood or steel which are opened at the top and bottom. The longer sides of moulds are projected out of the box to serve it as handles. If we take durability in consideration steel moulds are better than wooden moulds. In hand moulding again there are two types and they are

1. Ground moulded bricks
2. Table-moulded bricks

Ground moulded bricks

- In this process of ground moulding, first level the ground and sand or ash is sprinkled over it.
- Now place the wet mold in the ground and filled it with tempered clay and press hard to fill all corners of the mold. Extra clay is removed with metal strike or wood strike or with wire.
- The mold is then lifted up and we have raw brick in the ground. And again, wet the mold by dipping it in water and repeat the same process. The process of dipping mold every time to make bricks is called slop molding.

- Sometimes, the inside surface of mold is sprinkled with sand or ash instead of dipping in water this is called sand molding
- Frog mark of bricks are made by using a pair of pallet boards. Frog mark means the mark of depth which is placed on raw brick while molding. The depth may be 10mm to 20mm.
- Frog mark acts the trademark of manufacturing company and also it is useful to store mortar in it when the bricks is placed over it.

Table molded bricks

- This process is similar to ground molding process, but here the bricks are molded on the table of size 2m x 1m.
- Ground molding is economical when compared to table molding.

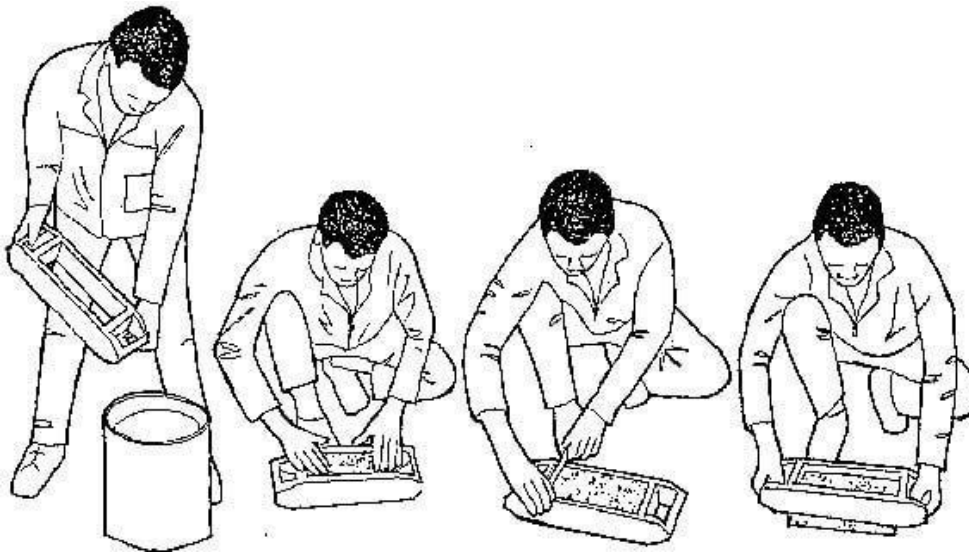

Machine molding of bricks

The bricks required are in large quantity, then machine molding is economical and also saves more time. Here also we are having two types of machines,

1. Plastic clay machines
2. Dry clay machines

Plastic clay machines These machines contain an opening in rectangular shape and when we place the tempered clay in to this machine it will come out through this opening. Now, the rectangular strips coming out the opening are cut by wires to get required thickness of brick. So, these are also called wire cut bricks. Now these raw bricks are ready for the drying process.

Dry clay machines Dry clay machines are more time saving machines. We can put the blended clay into these machines directly without tempering. Means tempering is also done in this machine by adding some water. When the required stiffness is obtained the clay is placed in mold and pressed hard and well-shaped bricks are delivered. These are called pressed bricks and these do not require drying they may directly sent to burning process.

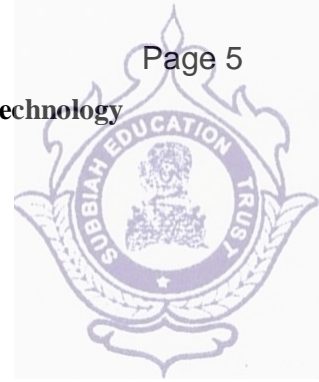

3. Drying of raw bricks

- After molding process, the bricks contain some amount of moisture in it. So, drying is to be done otherwise they may crack while burning. The drying of raw bricks is done by natural process.
- The bricks are laid in stacks. A stack consists 8 to 10 stairs. The bricks in these stacks should be arranged in such a way that circulation of air in between the bricks is free.
- The period of drying may be 3 to 10 days. It also depends upon the weather conditions.
- The drying yards are also prepared on higher level than the normal ground for the prevention of bricks from rain water.
- In Some situations, artificial drying is adopted under special dryers or hot gases.



4. Burning of bricks

- In the process of burning, the dried bricks are burned either in clamps (small scale) or kilns (large scale) up to certain degree temperature. In this stage, the bricks will gain hardness and strength so it is important stage in manufacturing of bricks.
- The temperature required for burning is about 1100°C. If they burnt beyond this limit they will be brittle and easy to break. If they burnt under this limit, they will not gain full strength and there is a chance to absorb moisture from the atmosphere.



- Hence burning should be done properly to meet the requirements of good brick.



BRICKS

Bricks are one of the oldest and most popular building materials. The reason for bricks being very popular and widely used construction material are,

*They are cheap

*They are durable

*They are easy to handle and work with

*In India, standard brick size is 190 mm x 90 mm x 90 mm as per the recommendation of BIS. With mortar thickness, the dimension of the brick becomes 200 mm x 100 mm x 100 mm which is also known as the nominal size of the modular brick .

CLASSIFICATION OF BRICKS

Based upon the physical and mechanical properties the bricks are classified into four types such as, first class, second class, third class, fourth class.

A) First class:

These are thoroughly burnt and are of deep red, cherry or copper colour.

The surface should be smooth and rectangular, with parallel, sharp and square corner.

These are free from cracks and stones

Water absorption should be 12 -15 % of its dry weight when immersed in cold water

The crushing strength of the brick should not be less than 10 N/mm² .

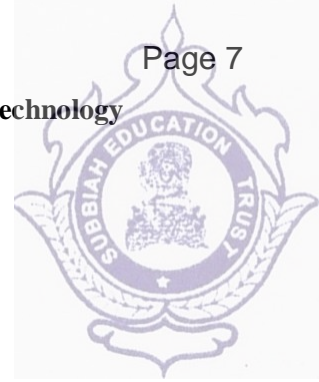

Uses: -First class bricks are recommended for pointing, exposed face work in masonry structures, flooring and reinforced brick work

B) Second class:

Small cracks and distortion are permitted

A little higher water absorption of about 16- 20% of its dry weight is allowed.

The crushing strength should not to be less than 7.0N/mm^2



Uses: - Second class are recommended for all important or unimportant hidden masonry works and centring of reinforced brick and RCC structures

C) Third class bricks:

These bricks are under burnt.

They are soft and light – colored.

They produce a dull sound when struck against each other

Water absorption is about 25% of dry weight

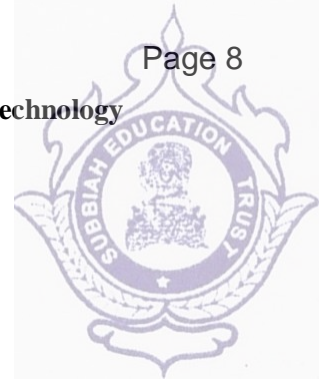

Uses: It is used for building temporary structures

D) Fourth class bricks:

These bricks are over burnt.

Badly distortion in size and shape Brittle in nature



Uses:

The ballast of such bricks is used for foundation and floors in lime concrete and road metal.

TESTS FOR BURNT CLAY BRICKS AS PER IS: 3495-1976

1. Test for compressive strength.

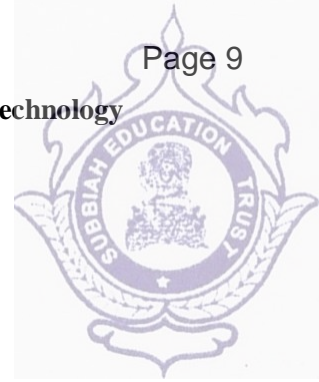

Test for compressive strength Test for compressive strength

According to Tests for burnt clay bricks as per IS: 3495-1976, Grind the two bed faces to provide smooth, even and parallel faces. Immerse the specimen in water at room temperature. Remove the specimen from water after 24 hours and drain out any surplus water at room temperature. Fill up flush the frog and all voids with cement mortar (1part cement and 1-part clean coarse sand of grade 3 mm and down), store under damp jute bags for 24 hours and then immerse in clean water for 3 days. Remove and wipe out any traces of moisture.

Place the specimen between two three plywood sheets, each 3 mm thick, with flat faces horizontal and mortar filled face facing upwards. The specimen sandwiched between the ply sheets are carefully centered between plates of compression testing machine. Apply axial load at a uniform rate of 140 kg/cm² per minute till failure. The maximum load at failure divided by the average area of the bed faces gives the compressive strength.

2. Test for water absorption.



Test for water absorption.

There are two tests to determine the test for water absorption, per cent by mass, for common burnt clay bricks viz., 24 hours immersion cold water test and the five-hour boiling water test. Each one of these is described below.

(a) 24-hour immersion cold water test.

Dry specimen is put in an oven maintained at a temperature of 105 to 115°C, till it attains substantially constant mass. Weight of specimen (W_1) is recorded after cooling it to room temperature. The dry specimen is then immersed completely in water at a temperature of $27 \pm 2^\circ\text{C}$ for 24 hours. Take the specimen out of water and wipe out all traces of water with damp cloth. Complete weighing of the specimen 3 minutes after specimen has been removed from water. Let this weight be (W_2).

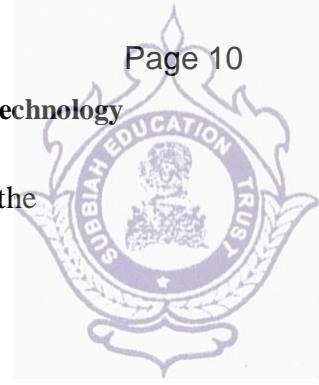

Water absorption per cent by mass, after 24 hours immersion in cold water is given by the relation:

$$\frac{W_2 - W_1}{W_1} \times 100$$

(b) Five-hour boiling water test.

The specimen is dried in an oven at 105 to 115°C till it attains constant mass. Cool the specimen at room temperature and record its weight (W_1). Now immerse the specimen into a tank of water in such a way that water can circulate all around the specimen. Stir the water off and on so that any air inside it is removed. Heat the water at such a rate that it starts boiling in an hour. Continue to boil it for five hours. Then allow it to cool to $27 \pm 5^\circ\text{C}$ by natural loss of heat for 16 to 19 hours. Take the specimen out of water, let the water drain out completely and wipe it with damp cloth. Complete the weighing of the specimen in three minutes (W_3). Water absorption, per cent by mass, is given by the relation:

$$\frac{W_3 - W_1}{W_1} \times 100$$

3. Test for efflorescence.



Test for efflorescence.

Test for efflorescence: Place on ends the bricks in 25 mm depth of water in a dish of minimum diameter 150 mm and depth 30 mm. The dish is made of glass, porcelain or of glazed stone work. The experiment is performed in a well-ventilated room (at 20 to 30°C) till all the water in the dish is either absorbed by the specimen or is evaporated. After the specimen have dried add similar quantity of water to the dish and let it too be absorbed by the specimen or evaporate as before. Examine the specimen for efflorescence after the second evaporation. Test for efflorescence: Presence of efflorescence shall be classified as nil, slight, moderate, heavy or serious as defined below:

(i) Nil.

When the deposit of efflorescence is imperceptible.

(ii) Slight.

When the deposit of efflorescence does not cover more than 10 per cent of the exposed area of the brick.

(iii) Moderate.

When the deposit of efflorescence is heavier than slight and does not cover more than 50 per cent of the exposed area of the brick surface. The deposit should not, however, powder or flake of the surface.

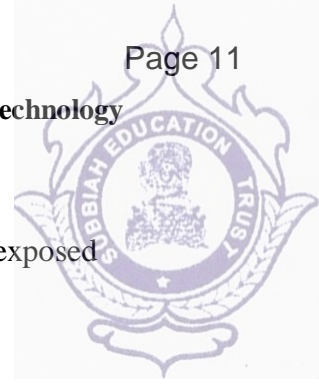
**(iv) Heavy.**

When the deposit of efflorescence salts is heavy and covers 50 per cent or more of the exposed area of brick surface. The deposit, however, does not powder or flake of the surface.

(v) Serious.

When the deposit of efflorescence salts is heavy and is accompanied by powdering and/or flaking of the exposed surfaces.

HOLLOW CONCRETE BLOCKS

[Hollow Concrete Blocks Confirms to IS: 2185 (Part 1): 2005]

Description of item:

This hollow Concrete Block have open or closed cavity and canbe used in the construction of load-bearing and non-load bearing partition walls.

Available Size: The nominal dimensions of concrete block with tolerance shall be asfollows:

Length: 400, 500 or 600 mm, variation of the unit shall not more than ± 5 mm

Height: 200 or 100 mm, variation of the unit shall not more than ± 3 mm

Width: 50, 75, 100, 150, 200, 250 or 300 mm, variation of the unit shall notmore than ± 3 mm.

Classification of Hollow Concrete Blocks: The hollow concrete blocks shall conform to following grade:

- a) *Grade A* — These are used as load bearing units and shall have a minimum block density of 1500 kg/m³. Minimum average compressive strengths of blocks shall be as per table.
- b) *Grade B* — These are also used as load bearing units and shall have a block density between 1100 kg/m³ and 1500 kg/m³. Minimum average compressive strengths of blocks shall be as per table.

Material of Hollow Concrete Blocks:

1. Cement: Cement complying with any of the following Indian Standards may be used:

a) 33 / 43/53 grade OPC/ Portland slag cement / Portland pozzalana cement / Supersulphated cement/ Rapid hardening Portland cement / White Portland cement or Hydrophobic Portland cement may be used.

b) When cement conforming to IS 269 or IS 8112 or IS 12269 is used, replacement of cement by fly ash conforming to IS 3812 (Part 1) may be permitted up to a limit of 25 percent.

2. Aggregates: The aggregates used in blocks shall conform to IS 383.

3. Fly Ash: Fly ash conforming to IS 3812 (Part 2) may be used for part replacement of fine aggregate up to a limit of 20 percent.

4. Water: The water used in made Hollow Concrete Blocks units shall be free from matter

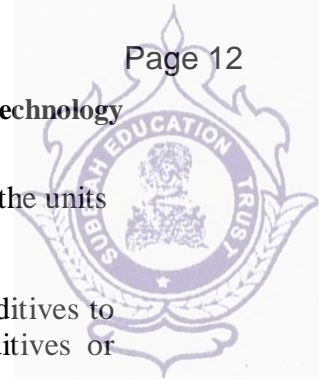

harmful to concrete or reinforcement, or matter likely to cause efflorescence in the units and shall conform to the requirements of IS 456.

5. Additives or Admixtures: Additives or admixtures may be added either as additives to the cement during manufacture, or as admixtures to the concrete mix. Additives or admixtures used in the manufacture of concrete masonry units may be:

- a) Where accelerating, water reducing, air-entraining and super plasticizer conforming to IS 9103,
- b) Waterproofing agents conforming to IS 2645, and
- c) Coloring pigments.

Where no Indian Standards apply; the additives or admixtures shall be shown by test or experience, to be not detrimental to the durability of the concrete.

Technical Specification: Technical specification of Hollow Concrete Blocks Confirming to IS: 2185 (Part 1): 2005 is as under:

Physical Requirements: -

1. Blocks Density

The block density of hollow concrete blocks, being the average of three units shall be as per table.

2. Compressive Strength

The minimum compressive strength at 28 days being the average of eight units, and the minimum compressive strength of individual units blocks shall be as per table.

3. Water Absorption

The water absorption, being the average of three units, shall not be more than 10 percent by mass.

4. Drying Shrinkage

The drying shrinkage of the units when unrestrained being the average of three units, shall not exceed 0.06 percent.

5. Moisture Movement

The moisture movement of the dried blocks on immersion in water, being the average of three units, shall not exceed 0.09 percent.

Table 1

Physical Requirements (Classification of Hollow Concrete Blocks and Compressive Strength)

Type	Grade	Density of Block	Minimum Average Compressive Strength of Units N/mm ²	Minimum Compressive Strength of Individual Units, N/mm ²
(1)	(2)	(3)	(4)	(5)
Hollow (open and closed cavity) load-bearing unit	A(3.5)	Not less than 1500	3.5	2.8
	A(4.5)		4.5	3.6
	A(5.5)		5.5	4.4
	A(7.0)		7.0	5.6
	A(8.5)		8.5	7.0

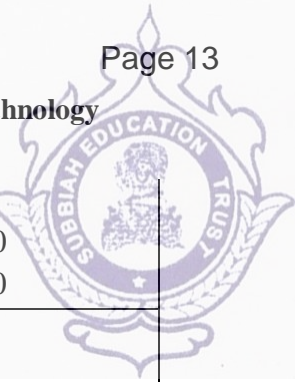

A(10.0)		10.0	8.0
A(12.5)		12.5	10.0
A(15.0)		15.0	12.0
B(3.5)	Less than 1500 but not less than 1100	3.5	2.8
B(5.0)		5.0	4.0

Use of Hollow Concrete Blocks: Concrete blocks are used in all types of masonry constructions, confirming to IS: 2572. Few examples are:

- Exterior load-bearing walls (both below and above grade)
- Interior load-bearing walls
- Fire walls and curtain walls
- Partitions and panel walls
- Backing for brick, stone, and other facings; Fireproofing over structural members
- Fire safe walls around stairwells, elevators, and enclosures
- Piers and columns; Retaining walls

Advantages of hollow concrete blocks:

1. The good concrete compacted by high pressure and vibration gives substantial strength to the block. Proper curing increase compressive strength of the blocks.
2. Low maintenance, Color and brilliance of masonry withstand outdoor elements.
3. Provide Thermal and sound insulation: The air in hollow of the block, does not allow outside heat or cold in the house. So, it keeps house cool in summer and warm in winter.
4. Environment Friendly, fly ash used as one of the raw materials.
5. No additional formwork or any special construction machinery is required for reinforcing the hollow block masonry, if required.
6. It is a faster and easier construction system, when compared to the conventional construction systems.
7. This construction system provides better acoustic and thermal insulation for the building.
8. Reduced Air Conducting Load: Approx. 50% saving.
9. No salt peter or leaching: Reduction in maintenance.

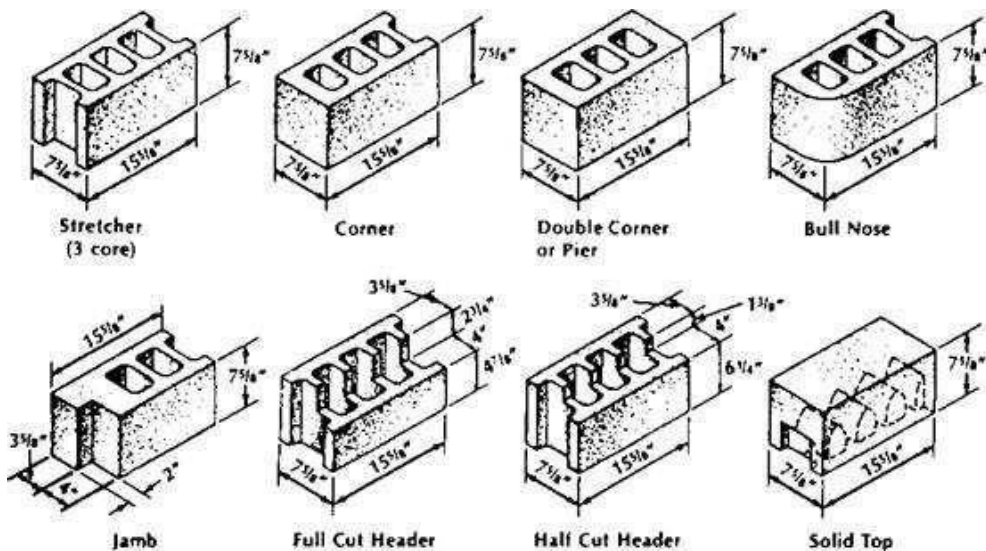



LIGHTWEIGHT CONCRETE

The first modern use of lightweight concrete (LWC) was recorded in 1917, when the American Emergency Fleet Corporation started building ships with this mixture due to its high strength and performance. Since then, LWC has become a common building material for constructing sturdy load-bearing walls, bridges, and sewer systems.

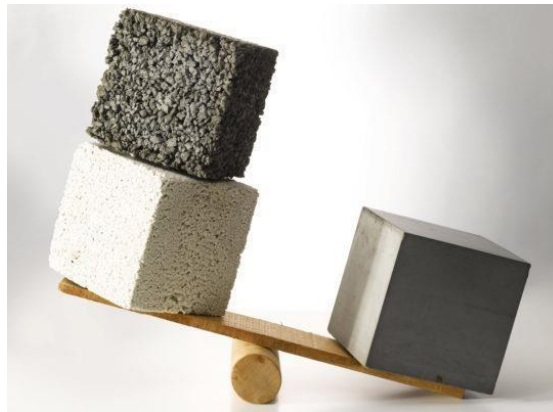

WHAT IS LIGHTWEIGHT CONCRETE?

Lightweight concrete is a mixture made with lightweight coarse aggregates such as shale, clay, or slate, which give it its characteristic low density. Structural lightweight concrete has an in-place density of 90 to 115 lb/ft³, whereas the density of regular weight concrete ranges from 140 to 150 lb/ft³. This makes lightweight concrete ideal for building modern structures that require minimal cross sections in the foundation. It is being increasingly used to build sleek foundations, and has emerged as a viable alternative to regular concrete.

Nevertheless, a higher compressive strength of 7000 to 10,000 psi can be attained with lightweight concrete. However, this may compromise the density of the mixture as it requires the addition of more pozzolans and water-reducing admixtures to the concrete.

DIFFERENCES BETWEEN NORMAL AND LIGHTWEIGHT CONCRETE

In contrast to traditional concrete, lightweight concrete has higher water content. The use of porous aggregates increases the time it takes to dry; hence, to offset this problem, aggregates are pre-soaked in water before being added into the cement.

As mentioned earlier, normal concrete can weigh between 140 to 150 Lbs/ft³ due to the presence of denser aggregates in their natural state. As a result, many believe normal concrete to be cheaper compared to LWC. However, projects made with normal concrete require additional material for framing, cladding, and steel reinforcements – ultimately increasing the overall cost. Hence, LWC remains a cost-effective construction material, especially for larger projects.

PRACTICAL APPLICATIONS OF LIGHTWEIGHT CONCRETE

One of the most popular structures built with lightweight concrete is the Bank of America Building in Charlotte, N.C. This shows how LWC can be used to build formidable structures, especially since the possibility of dead load being transferred from one floor to the next is greatly reduced.

LWC is thus ideal for constructing additional flooring on top of older or even newer structures, as it reduces the risk of collapse. As such, it can be used to successfully build bridges, decks, girders,

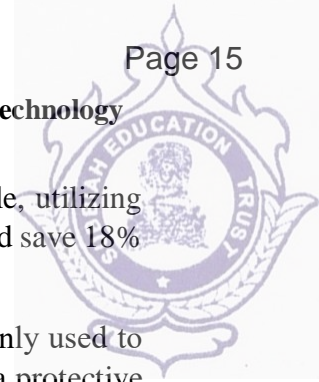

piers, precast constructions, and high-rise buildings with reduced density. For example, utilizing LWC in the Wabash River Bridge allowed builders to reduce project density by 17%, and save 18% in terms of cost.

Due to LWC's low thermal conductivity and higher heat resistance, it is now commonly used to insulate water pipes, walls, rooftops, etc. It guards against steel corrosion by forming a protective layer, which also works to insulate steel structures against rot. LWC is also commonly used to construct interstate and traffic lanes, without adding dead load to existing structures.

TYPES OF LIGHTWEIGHT CONCRETE

LIGHTWEIGHT AGGREGATE CONCRETE

This form of lightweight concrete is produced using porous and lightweight aggregates including Clay, Shale, Slate, Volcanic Pumice, Ash, or Perlite. Weaker aggregates may also be added to the mixture, which has an impact on its thermal conductivity; however, doing so may reduce its strength.

Lightweight aggregate is perfect for pre-cast concrete blocks or steel reinforcements. However, denser varieties show better bonding results between steel and concrete, along with enhanced protection from steel corrosion.

AERATED OR FOAMED CONCRETE

This type of lightweight concrete is also known as gas concrete or foamed concrete, since it is developed by introducing large voids into the mortar mass or concrete. Voids are typically injected through a chemical reaction, or with the use of an air entraining agent.

Aerated or foamed concrete does not require flattening, exhibits appropriate thermal insulation, and is self-compacting. This makes it ideal for use in hard-to-reach spaces and sewer systems.

NO-FINES CONCRETE

This form of concrete is developed by eliminating fine aggregates from the mixture; resulting in concrete which comprises of only large voids and coarse aggregates. This is why No-Fines concrete has better insulation and relatively reduced drying shrinkage.

No-Fines concrete is best-suited for load bearing walls and can be used for both indoor and outdoor constructions. However, this type of lightweight concrete should not be used with reinforced concrete, especially due to its lower density and cement content.

PROS & CONS OF LIGHTWEIGHT CONCRETE

Lightweight concrete is a flexible and easily transportable building material, and requires little support from materials such as steel or additional concrete. This makes it cost effective, especially for larger building projects.

Additionally, due to its low thermal conductivity and fire resistance, LWC is an ideal material for insulating against heat damage.

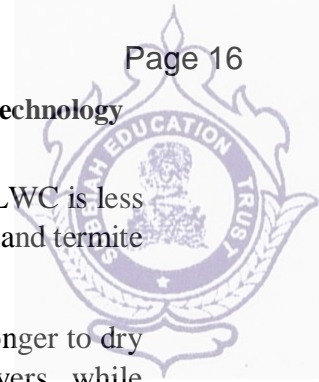

Despite its reduced density, structures built with LWC are unlikely to collapse. In fact, LWC is less likely to shrink compared to normal concrete and also shows increased resistance to rot and termite infestations.

However, LWC also has a few limitations. Since it has higher water content, it takes longer to dry out. Moreover, adding too much water can result in the formation of laitance layers, while compromising on water to offset this limitation may result in a weaker mixture.

Since LWC is also highly porous, it is difficult to place the mixture correctly. Another issue with LWC is that the cement tends to separate from aggregates if mixed incorrectly.

Building Stones Definition

Depending on the specific properties, different stones can be used for different building projects. As a precedent, stones like basalt and granite are considered superior to other types because they are strong and can resist the extremes of the climate and external loads. This property makes them suitable for large construction projects. On the other hand, some stones like gneiss can be used for small building projects due to low compressive strength and harmful materials.

Types of Building Stones used in Construction

There are many types of stones used for building constructions. Some of the most common types include granite, limestone, sandstone, slate, marble, travertine, basalt, quartzite, soapstone, and onyx. Each of these stones has its unique properties and aesthetic appeal, making them suitable for various applications, such as flooring, walls, countertops, and facades. Their durability, strength, and natural beauty make them a popular choice for both traditional and modern architecture. The list of 10 Types of Building Stones used in Construction are mentioned below

- Basalt
- Granite
- Sandstone
- Slate
- Limestone
- Laterite
- Marble
- Gneiss
- Quartzite
- Travertine

Common Types of Building Stones

There are some common types of building stones used in the civil engineering industry. Considering their unique structural properties, different stones are suitable for different engineering applications. The various types of building stones used in the civil engineering industry are given below:

Basalt

Fig 1: Basalt



- Basalt stones are also called Traps and have a dark grey to black colour.
- The grain size of basalt stone is between medium and fine.
- These stones are dense and the **compressive strength of Basalt is between 200 MPa to 350 MPa**, thereby making them suitable building materials for bridge piers, river walls, and dams.
- Basalt is resistant to weather and doesn't absorb water.
- Due to its hardness, it cannot be easily worked into fine shapes.
- Due to their engineering properties, these stones find applications in the construction of roads as an ingredient in making concrete.

Granite

Fig 2: Granite



- Granite is made up of crystalline grains that range from small to large in size.
- It is very tough, and its compression strength ranges between **100MPa and 250MPa**.
- It has a low absorption value, is non-porous, and has frost resistance.
- However, it is not good at resisting fire.
- Granite is easy to polish, and its color can be light grey to pink.
- Polished granite can be used for table tops, column and wall coverings, and flooring.

Sandstone

Fig 3: Sandstone



- It is made of quartz and feldspar and can be white, grey, red, buff, brown, yellow, or dark grey in colour.
- The **compressive strength of Sandstone ranges from 20 MPa to 170 MPa.**
- The specific gravity of Sandstone is between **1.8 to 2.7.**
- Sandstone can wear down by the adversities of weather and is thus not good for building construction.
- Sandstones and silica cement are used to build heavy structures. It is also used to build dams, bridge piers, river walls, and stonework.

Slate

Fig 4: Slate



- Slate is made up of minerals like quartz, mica, and clay and comes in the form of sheets of varying thicknesses.
- The colour of Slate can range from dark grey to greenish grey to purple grey to black
- The **compressive strength of Slate is 100MPa to 200MPa.**
- This building stone is made up of small grains, and its specific gravity is between **2.6 and 2.7.**
- This building stone finds applications in the manufacture of roof tiles, slabs, and roads.

Limestone

Fig 5: Limestone



- Limestone is a dense, compact, and fine-textured stone that is devoid of holes, cracks, and other surface deformations.
- Limestone has a specific gravity of **2.6**.
- It has a low compressive strength of **10 MPa to 50 MPa**.
- This stone is easy to dress and can take a very fine polish.
- Limestone is used to make floors, roofs, and roads, and it is also used as a base for cement.
- This stone shouldn't be used as facing stones in places prone to exposure to industrial gases as they have a low resistance to extreme gaseous effluents.

Laterite

Fig 6: Laterite



- Laterite can be reddish brown, yellow, brown, grey, or brownish red.
- This building stone needs to be necessarily plastered on the outside.
- It contains a large quantity of iron oxide.
- This stone can be easily broken up into small blocks and comes in both soft and hard forms.
- The compressive strength of Laterite is extremely low and ranges between **1.9 MPa and 2.3 MPa**.
- However, its strength increases with age.

Marble

Fig 7: Marble



- Marble stones are very strong, have a uniform texture, don't have many pores, and polish well.
- This stone comes in many colours, such as white and pink.
- Marble has a compressive strength between **70 and 75 MPa**.
- It is easy to cut and shape into different forms.
- It is used for the outside of columns, floors, and steps, as well as for decoration.

Gneiss

Fig 8: Gneiss



- This stone is characterized by a light grey, pink, purple, greenish grey, or dark grey colour.
- The **compressive strength of Gneiss ranges from 50MPa to 200MPa**.
- This type of stone is only used for small projects because it contains harmful substances that make it unsuitable for building construction.
- However, hard varieties of gneiss can be used in building projects.

Quartzite

Fig 9: Quartzite

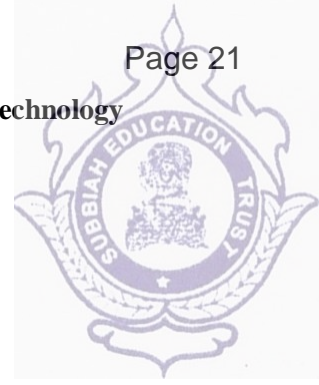

- Quartzite is mostly made up of small amounts of feldspar and mica and has a structure that ranges from fine to coarse grains.
- The **compressive strength of Quartzite ranges from 50MPa to 300MPa.**
- It has a **specific gravity of 2.7.**
- They come in different colors, such as white, grey, and yellowish colour.
- It is used to make building blocks, slabs, and concrete.

Travertine

Fig 10: Travertine



- This stone comes in many colors, from grey to coral-red, and can be polished to make it smooth and shiny.
- **Travertine has a specific gravity of 1.68**, and its compressive strength ranges between **80 and 120 MPa**. Its surface is characterised by pits and troughs, which make it porous and give it a circular texture.
- It is used to pave walkways, make garden paths, and also in courtyards.

Requirements of Good Building Stones

Building stones should have the following characteristics to make them viable for the construction industry:

Strength

The stones to be used in building constructions should have sufficient compressive strength. The compressive strength stones should lie between **60 to 200N/mm²** to make them viable for building construction.

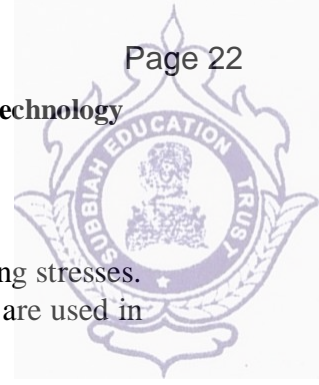

Hardness

Stones utilized for flooring and pavements should be susceptible to abrasive and wearing stresses. The hardness of stones should lie between 14 - 17. Stones of hardness greater than 17 are used in pavement construction.

Specific Gravity

Specific gravity is a direct indicator of the weight and strength of the stone. Stones with high specific gravity are preferred for large engineering projects like dams, retaining walls, etc. Notably, the specific gravity of stones deemed fit to be a building material should be between 2.4 and 2.8.

Appearance

The appearance is given precedence when the stones are to be used in fine works. Such stones should have a smooth surface and should be conducive to the application of polish on their surface.

Workability

Building stones should have sufficient workability, i.e., the easy of being used at the construction site during cutting, dressing, and during their re-shaping.

Fire resistance

The stones to be used as building materials should have sufficient fire resistance. Stones containing a sufficient quantity of Quartz have a tendency to break on the application of excessive heat. On the contrary, limestone has sufficient fire resistance.

There are various tests on building stones to know its properties and suitability for various construction works. Tests on building stones provides physical and chemical properties as well as strength and hardness properties.

Tests on Building Stones

Following are different tests on building stones:

1. Acid test
2. Attrition test
3. Crushing test
4. Crystalline test
5. Freezing and thawing test
6. Hardness Test
7. Impact test
8. Water absorption test
9. Microscopic Test
10. Smith's Test



Acid Test on Building Stone

This test is carried out to understand the presence of calcium carbonate in building stone. A sample of stone weighing about 50 to 100 gm is taken. It is placed in a solution of hydrophobic acid having strength of one percent and is kept there for seven days. Solution is agitated at intervals. A good building stone maintains its sharp edges and keeps its surface free from powder at the end of this period. If the edges are broken and powder is formed on the surface, it indicates the presence of calcium carbonate and such a stone will have poor weathering quality. This test is usually carried out on sandstones.

Attrition Test on Building Stone

This test is done to find out the rate of wear of stones, which are used in road construction. The results of the test indicate the resisting power of stones against the grinding action under traffic. **The following procedure is adopted:**

1. Samples of stones is broken into pieces about 60mm size.
2. Such pieces, weighing 5 kg are put in both the cylinders of Devil's attrition test machine. Diameter and length of cylinder are respectively 20 cm and 34 cm.
3. Cylinders are closed. Their axes make an angle of 30 degree with the horizontal.
4. Cylinders are rotated about the horizontal axis for 5 hours at the rate of 30 rpm.
5. After this period, the contents are taken out from the cylinders and they are passed through a sieve of 1.5mm mesh.
6. Quality of material which is retained on the sieve is weighed.
7. Percentage wear worked out as follows:

Percentage wear = (Loss in Weight/Initial Weight) x 100

Crushing Test on Building Stone

Samples of stone is cut into cubes of size 40 x 40 x 40 mm sizes of cubes are finely dressed and finished. Maximum number of specimens to be tested is three. Such specimen should be placed in water for about 72 hours prior to test and therefore tested in saturated condition. Load bearing surface is then covered with plaster of Paris of about 5mm thick plywood. Load is applied axially

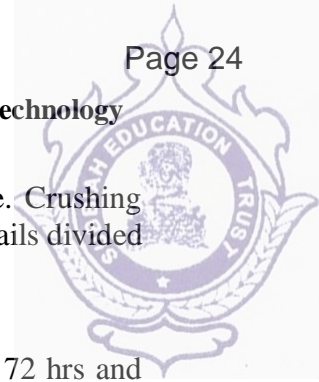

on the cube in a crushing test machine. Rate of loading is 140 kg/sq.cm per minute. Crushing strength of the stone per unit area is the maximum load at which the sample crushes or fails divided by the area of the bearing face of the specimen.

Crystalline Test on Building Stone

At least four cubes of stone with side as 40mm are taken. They are dried for 72 hrs and weighed. They are then immersed in 14% solution of Na₂SO₄ for 2 hours. They are dried at 100 degree C and weighed. Difference in weight is noted. This procedure of drying, weighing, immersion and reweighing is repeated at least 5 times. Each time, change in weight is noted and it is expressed as a percentage of original weight. Crystallization of CaSO₄ in pores of stone causes decay of stone due to weathering. But as CaSO₄ has low solubility in water, it is not adopted in this test.

Freezing and thawing test

Stone specimen is kept immersed in water for 24 hours. It is then placed in a freezing machine at -12 deg C for 24 hours. Then it is thawed or warmed at atmospheric temperature. This should be done in shade to prevent any effect due to wind, sun rays, rain etc. this procedure is repeated several times and the behaviour of stone is carefully observed.

Hardness Test on Building Stone

For determining the hardness of a stone, the test is carried out as follows:

1. A cylinder of diameter 25mm and height 25mm is taken out from the sample of stone.
2. It is weighed.
3. The sample is placed in Dorry's testing machine and it is subjected to a pressure of 1250 gm.
4. Annular steel disc machine is then rotated at a speed of 28 rpm.
5. During the rotation of the disc, coarse sand of standard specification is sprinkled on the top of disc.
6. After 1000 revolutions, specimen is taken out and weighed.

Lime – Preparation of lime mortar

Lime mortar is made by mixing lime, sand and water. Lime used for mortar may be fat lime (quick or hydrated lime) or hydraulic lime. Fat lime has high calcium oxide content. Its hardening depends on loss of water and absorption of carbon dioxide from the atmosphere and possible recrystallization in due course. Hydraulic lime contains silica, alumina and iron oxide in small quantities. When mixed with water it forms putty or mortar having the property of setting and hardening under water. Slaked fat lime is used to prepare mortar for plastering, while hydraulic lime is used for masonry construction and are most suitable for construction of chimneys and lightly loaded superstructure of buildings.

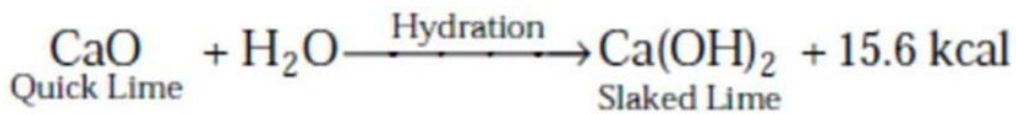
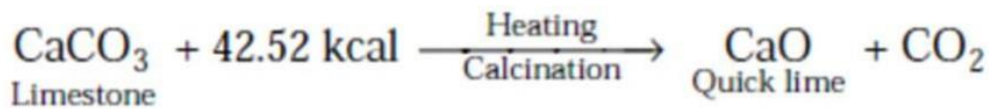

UNIT II

OTHER MATERIALS

CERAMICS

Ceramics are classified as inorganic and non-metallic materials that are essential to our daily lifestyle. Ceramic and materials engineers are the people who design the processes in which these products can be made, create new types of ceramic products, and find different uses for ceramic products in everyday life.

Ceramics are all around us. This category of materials includes things like tile, bricks, plates, glass, and toilets. Ceramics can be found in products like watches (quartz tuning forks-the time keeping devices in watches), snow skies (piezoelectric-ceramics that stress when a voltage is applied to them), automobiles (sparkplugs and ceramic engine parts found in race cars), and phone lines. They can also be found on space shuttles, appliances (enamel coatings), and airplanes (nose cones). Depending on their method of formation, ceramics can be dense or lightweight. Typically, they will demonstrate excellent strength and hardness properties; however, they are often brittle in nature. Ceramics can also be formed to serve as electrically conductive materials, objects allowing electricity to pass through their mass, or insulators, materials preventing the flow of electricity. Some ceramics, like superconductors, also display magnetic properties.

Ceramics are generally made by taking mixtures of clay, earthen elements, powders, and water and shaping them into desired forms. Once the ceramic has been shaped, it is fired in a high temperature oven known as a kiln. Often, ceramics are covered in decorative, waterproof, paint-like substances known as glazes.

Properties, they are used for a multitude of applications. In general, most ceramics are:



- hard,
- wear-resistant,
- brittle,
- refractory,
- thermal insulators,
- electrical insulators,
- nonmagnetic,
- oxidation resistant,
- prone to thermal shock, and
- chemically stable.

Composite Material

Firstly, composite materials are something that is composed of a minimum of two materials. It combines to serve properties superior to the properties of the individual constituents.

Many of the component materials and different processes that we can use for making composites versatile and efficient at an extreme level.

Definition of Composite Material

Two or more materials make up a composite material with significantly different chemical or physical properties when they combine. As a result, it produces material different characteristics from the individual components.

The individual components remain separate and distinct with the final structure, differentiating the composites from the mixtures and the solid solutions as well.

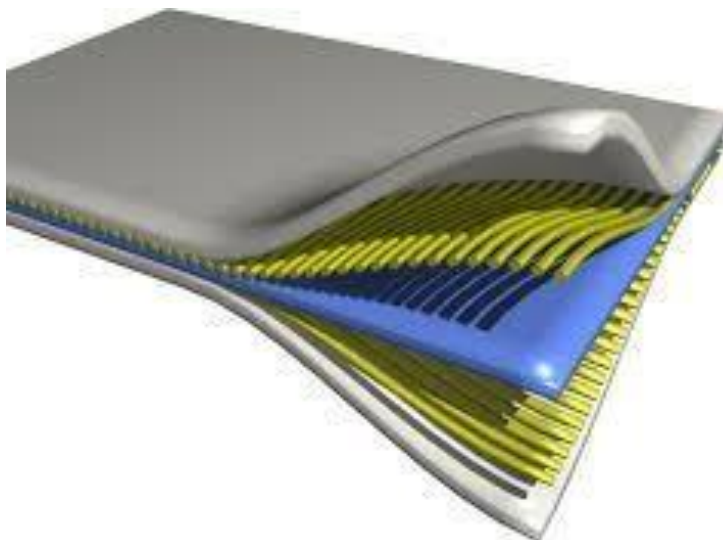

It prefers new material for many reasons. Some usual examples consist of materials which are that are lighter, stronger or less expensive while comparing it with traditional materials.

More recently, researchers are now actively including actuation, sensing, computation and last but not the least communications in the composites. These are the robotic materials.



Typical Composite Materials Consist of

- Masonry and the reinforced concrete.
- Composite wood, for example, Ply Wood.
- Reinforced plastics, for example, fiberglass
- Ceramic matrix composites.
- Metal matrix composites.
- Various other advanced composite materials.

Application of Composite Materials

These materials basically come in use for the construction of the bridges, buildings, and many other structures.

Such as swimming pool panels, boat hulls, bodies of some racing cars, stalls of the shower, bathtubs, cultured marble sinks, storage tanks, imitation granites, and countertops.

The best examples perform routinely on the spacecraft and the aircraft in a demanding environment.

Growth in the Composite Industry

It is an exciting industry for working because of the new materials, applications, and processes develop every time. Likewise using the hybrid virgin and fibres after recycling results in manufacturing it faster and with more automation.

The global level market of the composite materials is growing at a rate of about 5 percent per year. On the other hand, the demand for carbon fibre is growing at a rate of 12 percent per year approx. Moreover, around 1500 British companies are also participating in this growth.

Types of Composite Materials

The classification of the composite materials depends on the type of reinforcement they are using. These reinforcements are set into a matrix that holds them together.

This reinforcement comes in use for strengthening the composite. For example, in a brick of mud. The mud is the matrix and therefore the reinforcement is the straw.

A common type of composite includes random-fibre or short fibre reinforcement, continuous fibre or the long fibre reinforcement, particulate reinforcement, filler reinforcement, and the flake reinforcement.

Mud bricks for Construction

These are the examples of composite materials by the ancient humans in the early times. A brick made from only the mud is sturdy and resistant to the compression, but it has less flexibility, and it breaks when bent.

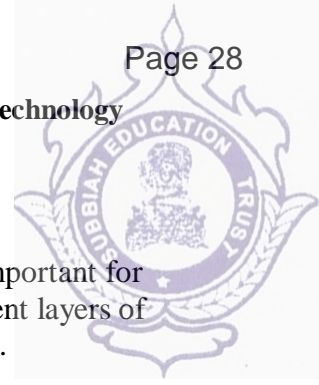

Fibreglass

Small glass shards make it up and resin and other components hold it together. It is important for making body kits in the automobile industries. The body shell of the car is made of different layers of fibre glasses. It is also a less expensive alternative when we compare it to other materials.

Natural composites

Composites that are easily found in nature are natural composites. For example, wood. These fibres are found in cotton and thread, but the wood is much tougher because of the bonding power that it gets from the lignin. Many types of large rocks also fall under the category of natural composites.

FALSE CEILING

A false ceiling is a secondary ceiling that is suspended from the structural ceiling of the home, and is made in materials such as POP, gypsum, wood, glass, PVC and so on. These materials are long lasting, look good and add to the aesthetic appeal of the space.

Some popular types of false ceiling panels include:

1. Gypsum false ceilings.
2. Plaster of Paris false ceilings.
3. Wood false ceilings.
4. Metal false ceilings.
5. PVC (Polyvinyl Chloride) false ceilings.
6. Fibre false ceilings.
7. Glass false ceilings.
8. Fabric and synthetic leather false ceilings.

1. Gypsum

Gypsum has emerged as the most popular false ceiling material. It is available in the form of square boards that are factory-manufactured.

Properties

1. Gypsum boards are very strong and highly durable.
2. The best part about using gypsum boards is that they ensure quick and easy installation and generate very little dust during execution. Also, since the gypsum boards are available in large sizes, very few joint lines are visible in the ceiling.
3. Gypsum is a fire-resistant material.
4. Gypsum has very good acoustic properties and it provides good sound proofing.
5. These ceilings provide good thermal insulation.
6. Gypsum boards have a very smooth factory-produced finish. The ceiling can be further finished with paint, laminate or wallpaper.

Cons

1. In case there is any damage caused to the ceiling, it needs to be broken down completely as it cannot be repaired.
2. It is not suitable for moisture-laden areas such as the bathroom or the outdoors, because gypsum has the tendency to warp. It may also fall prey to fungal growth.



2. POP (Plaster of Paris)

POP is a quick-setting white powder that hardens quickly when mixed with water. This mixture is applied to a chicken mesh, allowed to dry and then fixed as the false ceiling.

Properties

1. POP is a durable false ceiling material.
2. It forms a smooth finish which does not show cracks because the same material is used for closing all the joint lines. Paints settle very well on the POP ceiling.
3. POP is a flexible material and one can achieve any shape with POP.
4. It is one of the cheapest false ceiling materials.

Cons

1. The process of mixing the POP with water and letting it dry on site is a very time-consuming and messy process.

Note: Only skilled workers should be employed to fabricate the POP ceiling because they will know the correct proportions for mixing POP with water.

3. Wood

Bring in a warm, rustic or high-end modern look to your decor with wooden ceilings. These ceilings are installed by fixing wooden blocks or panels on the structural ceiling and finishing it with veneer or wood polish.

Properties

1. Wooden ceilings stand out because of the natural textures and grain patterns of wood. These ceilings go well with both traditional and modern decors.

Cons

1. Wooden false ceilings are very expensive.
2. Wooden ceilings can get infested with termites.
3. Wood has the tendency to expand and contract; hence it is prone to warping and cracking.

4. Metal

Metal ceilings comprise metal panels suspended in a visible grid; the metal panels are available in the form of ready-to-install tiles.

Properties

1. Metal ceilings are very strong and durable.
2. These ceilings are maintenance-free as they do not crack or warp over time.
3. Metal has a very good sheen, which imparts a high-end shiny look to the decor.

Cons

1. Metal ceiling panels are very expensive.
2. These panels should be finished with a protective coating that shall protect the metal sheets from corrosion.

5. PVC

If you are looking for a water-resistant false ceiling material, go for PVC (polyvinyl chloride) ceiling panels.

Properties

1. PVC sheets are lightweight, durable and sturdy, which do not require any finishing or painting once installed. They last for years without warping or bending.

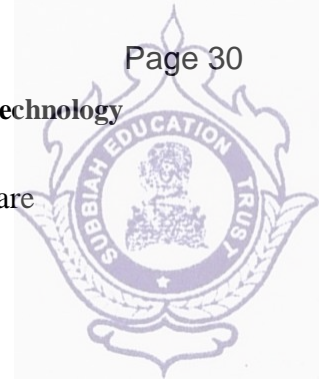

2. The water-resistant nature of the PVC sheets prevents water absorption. Hence, they are resistant to mold and mildew, especially in areas with damp conditions.
3. PVC panels are easy to install and are highly affordable.
4. They are available in many colors.

Cons

1. PVC false ceiling panels can give a plastic look.
2. Another major drawback is that PVC false ceiling panels are not fire-resistant and may get damaged when subjected to heat.

FIBRE GLASS REINFORCED PLASTIC

Fibre Glass Reinforced Plastic (FGRP) or Glass Fibre Reinforced Plastic is a combination of glass fibres and plastics.

FGRP is known for its mechanical strength and a popular choice when it comes to corrosion resistance. Furthermore, FGRP is light weight, has excellent temperature-resistant properties, offers thermal insulation and can be formed in complex shapes. FGRP products are easy to repair and hardly require any maintenance. FGRP products are known for their smooth internal surface and seamless shapes, providing perfect flow of products.

Properties	GFRP
	Unidirectional
Weight of fibre (g/m ²)	920
Fibre thickness (mm)	0.90
Nominal thickness per layer (mm)	1.5
Fibre tensile strength (N/mm ²)	3400
Tensile modulus (N/mm ²)	73000

Properties of Fiber Glass Reinforced Plastic

Glass-Reinforced Plastic (GFRP), also known as glass fiber-reinforced plastic (GFRP) is a lightweight, extremely strong, and robust material. The properties of GFRP are listed below.

Design Freedom

The practical uses of GFRP are almost endless and give designers much more creative freedom. GFRP's unique physical properties allow it to be easily tooled, molded and manufactured

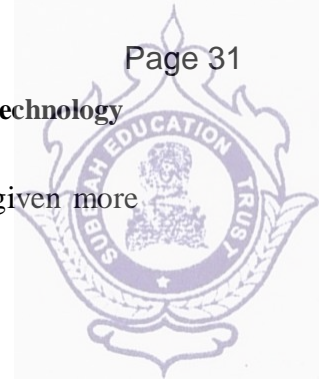

to meet almost any specifications. Low manufacturing costs allow the design to be given more priority.

Versatile and Affordable

The lightweight strength of GFRP makes it a popular choice for manufacturing. GFRP reduces the products weight and requires less maintenance making it highly attractive over more traditional materials like timber, metal or brick. GFRP is an affordable solution as it is cheap to design, manufacture and install.

Strong and Durable

GFRP has a high strength to weight ratio and high flexural strength; this means it is a lightweight material that is also super strong.

GFRP also has high resistance to:

- ultraviolet light
- extreme temperatures
- salt air
- chemicals including most acids

Products made from GFRP require very little maintenance - no rust, no painting, no wood rot. GFRP is also non-corrosive and has a much longer life expectancy when compared to other construction materials like stainless steel. In harsh environments, GFRP is a better choice over metal, wood or plastic.

Appearance

GFRP products can be produced in many finishes, textures and colours including brick and stone effect. Also, GFRP products have sleek edges and a modern molded look.

Dielectric

GFRP is non-conductive, RF transparent and helps to insulate against electromagnetic fields, making GFRP the obvious choice for electrical and electronic equipment storage like electrical enclosures and cabinets.

Acoustic Properties

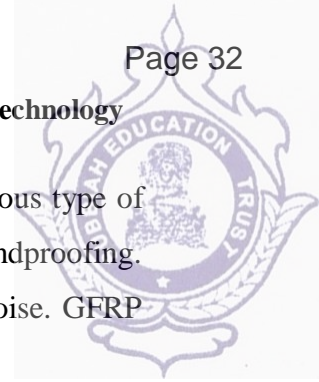

GFRP provides better soundproofing when compared to plastic or metal. Various type of sound deadening materials can be added between the layers of GFRP to increase soundproofing. This makes GFRP ideal for use in housings or buildings when you need to reduce noise. GFRP parts hold their shapes even under mechanical and environmental stresses.

Good electrical and mechanical properties

Glass Fibre Reinforced Plastic - GFRP - offers the engineer many outstanding properties. They have good natural electrical characteristics, a low coefficient of expansion and are resistant to corrosion and weathering. Their mechanical strength is high and GRP mouldings possess excellent tensile and bending strengths and stiffness. And all these properties can be obtained in a single moulding that often costs less than the same component fabricated from or manufactured in conventional materials.

Style and Shape

The ease with which complex shapes, double curvatures, etc. can be produced, frees the engineering designer from the often-frustrating limitations of other materials. There is also greater flexibility in choice of colour. Pigments can be introduced to provide almost any tone – matching or contrasting.

Uses of Fiber Reinforced Glass Plastic

Fiber Glass reinforced plastic is used in Building constructions.

- FGRP which is mat made used as reinforcing membrane in water proofing and damp proofing.
- It is used as roof sheets for coverings.
- It is even used in water tanks, easy to install and can be used inside and outside the buildings.
- It can also be used for strengthening reinforced concrete bridge decks, slabs, etc.
- Fiber Glass Reinforced Plastics, FRP is an excellent choice of material for the construction of chemical storage tanks, piping systems, apparatus and other types of industrial process equipment. The FRP material properties beat many conventional

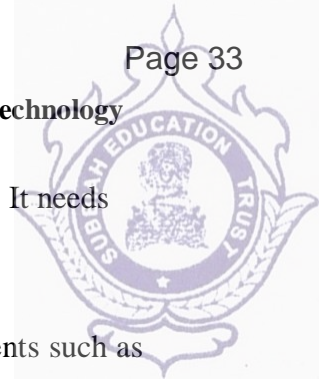

materials, such as steel when it comes to chemical and corrosion resistance. It needs only little maintenance and has a long product life time.

- Glass-reinforced plastics are also used to produce house building components such as roofing laminate, door surrounds, over-door canopies, window canopies and dormers, chimneys, coping systems, and heads with keystones and sills. The material's reduced weight and easier handling, compared to wood or metal, allows faster installation. Mass-produced fiberglass brick-effect panels can be used in the construction of composite housing, and can include insulation to reduce heat loss.

GEOMEMBRANE

A geomembrane is very low permeability synthetic membrane liner or barrier used with any geotechnical engineering related material so as to control fluid (liquid or gas) migration in a human-made project, structure, or system. Geomembranes are made from relatively thin continuous polymeric sheets, but they can also be made from the impregnation of geotextiles with asphalt, elastomer or polymer sprays, or as multilayered bitumen geo composites.

Manufacturing

The manufacturing of geomembranes begins with the production of the raw materials, which include the polymer resin, and various additives such as antioxidants, plasticizers, fillers, carbon black, and lubricants (as a processing aid). These raw materials (i.e., the "formulation") are then processed into sheets of various widths and thickness by extrusion, calendaring, and/or spread coating.

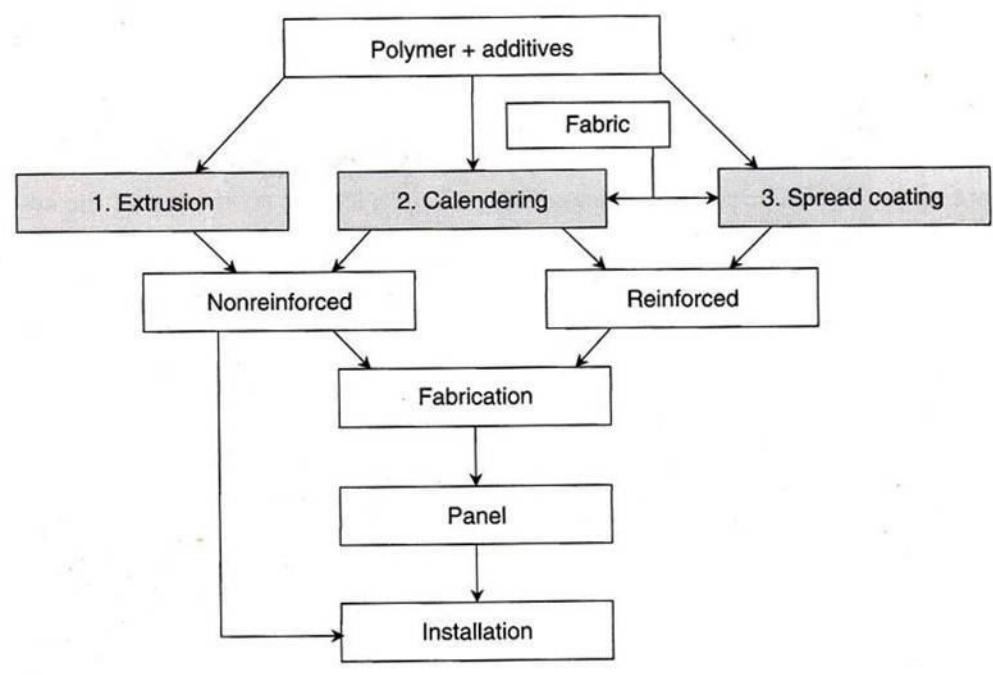

Geomembranes dominate the sales of geosynthetic products, and can be summarized as follows.

- high-density polyethylene (HDPE)
- linear low-density polyethylene (LLDPE)
- polyvinyl chloride (PVC)



- flexible polypropylene (fPP)
- chlorosulfonated polyethylene (CSPE)
- ethylene propylene diene terpolymer (EPDM)

Physical properties

The main physical properties of geomembranes in the as-manufactured state are:

- Thickness (smooth sheet, textured, asperity height)
- Density
- Melt flow index
- Mass per unit area (weight)
- Vapor transmission (water and solvent).

Mechanical properties

There are a number of mechanical tests that have been developed to determine the strength of polymeric sheet materials. Many have been adopted for use in evaluating geomembranes. They represent both quality control and design, i.e., index versus performance tests.

- tensile strength and elongation (index, wide width, axisymmetric, and seams)
- tear resistance
- impact resistance
- puncture resistance
- interface shear strength
- anchorage strength
- stress cracking (constant load and single point).

Applications

Geomembranes have been used in the following environmental, geotechnical, hydraulic, transportation, and private development applications:

-
- As liners for potable water
 - As liners for reserve water (e.g., safe shutdown of nuclear facilities)
 - As liners for waste liquids (e.g., sewage sludge)
 - Liners for radioactive or hazardous waste liquid
 - As liners for secondary containment of underground storage tanks
 - As liners for solar ponds
 - As liners for brine solutions
 - As liners for the agriculture industry
 - As liners for the aquaculture industry, such as fish/shrimp pond
 - As liners for golf course water holes and sand bunkers
 - As liners for all types of decorative and architectural ponds
 - As liners for water conveyance canals
 - As liners for various waste conveyance canals
 - As liners for primary, secondary, and/or tertiary solid-waste landfills and waste piles
 - As liners for heap leach pads
 - As covers (caps) for solid-waste landfills
 - As covers for aerobic and anaerobic manure digesters in the agriculture industry
 - As covers for power plant coal ash
 - As liners for vertical walls: single or double with leak detection
 - As cutoffs within zoned earth dams for seepage control
 - As linings for emergency spillways

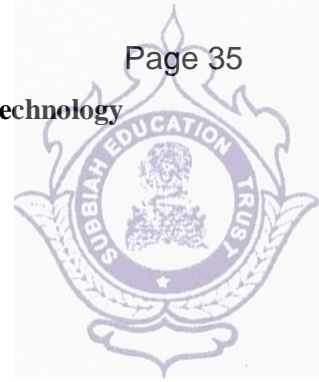

- As waterproofing liners within tunnels and pipelines
- As waterproof facing of earth and rockfill dams
- As waterproof facing for roller compacted concrete dams
- As waterproof facing for masonry and concrete dams
- Within cofferdams for seepage control
- As floating reservoirs for seepage control
- As floating reservoir covers for preventing pollution
- To contain and transport liquids in trucks
- To contain and transport potable water and other liquids in the ocean
- As a barrier to odors from landfills
- As a barrier to vapors (radon, hydrocarbons, etc.) beneath buildings
- To control expansive soils
- To control frost-susceptible soils
- To shield sinkhole-susceptible areas from flowing water
- To prevent infiltration of water in sensitive areas
- To form barrier tubes as dams
- To face structural supports as temporary cofferdams
- To conduct water flow into preferred paths
- Beneath highways to prevent pollution from deicing salts
- Beneath and adjacent to highways to capture hazardous liquid spills
- As containment structures for temporary surcharges
- To aid in establishing uniformity of subsurface compressibility and subsidence
- Beneath asphalt overlays as a waterproofing layer
- To contain seepage losses in existing above-ground tanks
- As flexible forms where loss of material cannot be allowed.

GEO TEXTILE

A strong synthetic fabric usually used in civil engineering construction projects (such as highway or dam building) that stabilizes loose soil and prevents erosion.

What is geo textile made of?

Geotextiles refers to a permeable synthetic textile material. Generally it is produced from polyester or polypropylene polymers

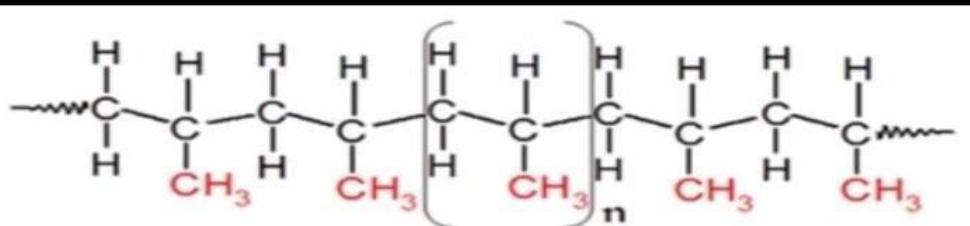

Why do we use geotextile?

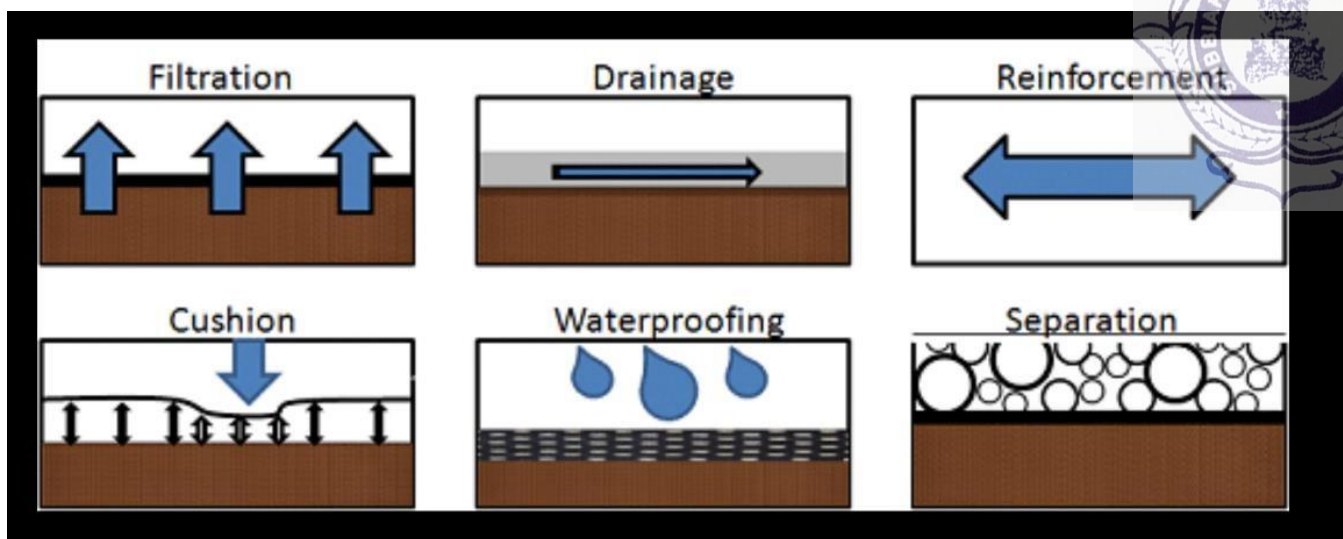
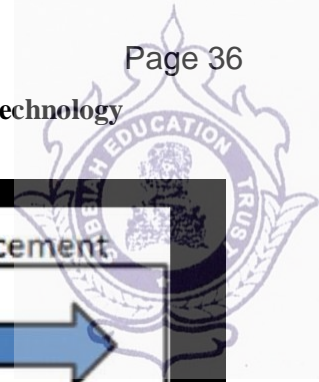

	<p>SEPARATION The use of a geotextile to prevent the intermixing of dissimilar soil layers.</p>		<p>DRAINAGE The use of a geosynthetic layer to collect and transport fluids within its own thickness.</p>
	<p>FILTRATION The use of a geotextile to allow the passage of fluids (most commonly water) while preventing the uncontrolled passage of soil particles.</p>		<p>PROTECTION The use of a geosynthetic material as a stress reduction layer to prevent or reduce damage to an adjacent surface or layer.</p>
	<p>REINFORCEMENT The use of the tensile properties of a geosynthetic material to resist stresses or contain deformations in soil structures.</p>		<p>EROSION CONTROL The use of a geosynthetic material to prevent the loss of soil particles from water erosion.</p>

How are geotextiles used in civil engineering?

The geotextile acts as a separator, allowing water from soft natural soil to pass into a free-draining construction soil, which allows the natural soil to consolidate, thereby gaining strength and providing a more suitable surface for foundations.

Types of Geotextiles

Geotextiles are made from polymers such as polypropylene and polyester. They are divided into three categories, according to their manufacturing process:

- Woven fabric
- Nonwoven fabric
- Knitted fabric

Other geosynthetics include geonets, geocells, geomembranes, geogrids, etc.

Woven fabric geotextiles are the most common, and their manufacturing methods are similar to those of clothing textiles. This type of geotextile is made from two sets of parallel threads or yarns.

Nonwoven geotextiles are made from continuous yarn filaments or short staple fibers. They are bonded with thermal, chemical or mechanical techniques, or a combination of techniques.



Knitted geotextiles are created by interlocking a series of yarn loops together. These geosynthetics are made by combining the knitting technique with other methods like weaving.

Main Functions of Geotextiles



Geotextiles are typically used to improve soil characteristics before building embankments, roads, pipelines and earth-retaining structures. Geotextiles have several functions, which include filtration, drainage, reinforcement, cushioning, waterproofing and separation.

Geotextile Separation

This is the main reason why geotextiles are used in construction. When a geotextile is installed between two different soils, it will prevent intermixing when water gets into the soil strata. This way, the required soil characteristics can be conserved. By separating fine subgrade soil from the aggregates, which is the case of roads, the geotextile preserves the drainage properties and strength of the base material.

These geotextiles have special thickness and permeability properties, to prevent soil contamination and to allow water flow without compromising structural integrity. Some application areas of geotextiles include:

- Between landfills and stone base courses
- Between subgrade and base in paved and unpaved roads
- Between subgrade in railroads
- Between geomembranes and sand drainage layers

Geotextile Filtration

The filtration properties of geotextiles are used when there is a need for water to move in both directions. These types of geotextiles can be woven or nonwoven, and they are used to prevent fine aggregates from moving between the soil layers.

The two main properties of geotextiles that involve infiltration are porosity and permeability. Depending on these properties, geotextiles can also promote the lateral flow of water, dissipating kinetic energy from the capillary rise of groundwater. Applications of this type of geotextile can be both vertical and horizontal, helping solve drainage problems along roads and structures.

Geotextile Reinforcement

There are three key factors when designing geotextiles to improve soil characteristics:

- Friction or movement restraint between the geotextile and the soil
- Supporting any loads present
- Increasing shear strength

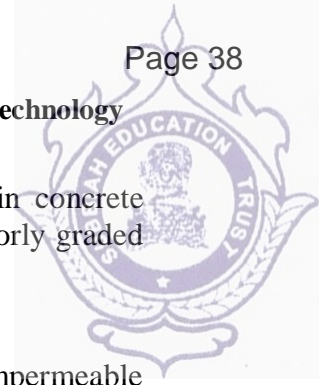

The role of geotextile reinforcement is comparable to the function of steel bars in concrete construction. Geotextiles are used for embankments and roads that are built over poorly graded soils, implementing the design parameters provided by a geotechnical engineer.

Geotextile Sealing

Geotextile fabrics can be impregnated with asphalt or other mixes, which makes them impermeable and capable of restricting the vertical flow of water. For this application, geotextiles must be nonwoven. Impermeable geotextiles can be used to prevent contamination of soil or groundwaters from pollutants above, also they may help in preventing the loss of potable water due to evaporation.

Geotextile Applications in Civil Engineering Projects



The scope of geotextiles in the civil engineering field is very vast, including the following applications:

- **Roads:** Geotextiles are widely used in road construction, reinforcing the soil by adding tensile strength. Geotextiles can be used as a rapid dewatering layer in the roadbed.
- **Railways:** Geotextiles are used to separate the individual soil layers, without impeding groundwater circulation where the ground is unstable. This also keeps the layer materials from shifting sideways under the constant shocks and vibrations from passing trains.
- **Agriculture:** Nonwoven fabrics are used for mud control, to improve paths and trails used by cattle or light traffic.
- **Drainage:** Geotextiles are used as filtering mechanisms for drainage in roads, highways, earth dams, reservoirs, retaining walls, drainage trenches, and many other applications.
- **Coastal work:** Geotextiles can help prevent erosion in river banks, canals and other bodies of water.

Other common applications of geotextiles include landfills, sidewalks, parking lots, green areas, recreational facilities, pipe trenches and duct banks. Since geotextiles help preserve soil conditions, they have a positive environmental impact.

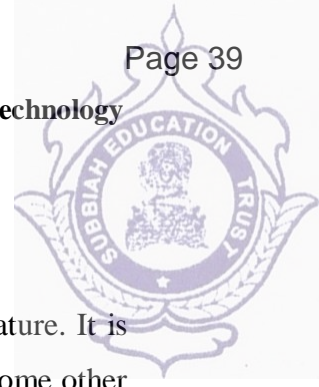

GLASS

Glasses and its Types, Properties, Use and Application of Glasses

Glass is a hard substance which may be transparent or translucent and brittle in nature. It is manufactured by fusion process. In this process sand is fused with lime, soda and some other admixtures and then cooled rapidly. Glass is used in construction purpose and architectural purpose in engineering. There are various types of glass used in construction for different purposes

Properties of Glass

1. Transparency
2. Strength
3. Workability
4. Transmittance
5. U value
6. Recycle property

1. Transparency of Glass

Transparency is the main property of glass which allows the vision of outside world through it. The transparency of glass can be from both sides or from one side only. In one side transparency, glass behaves like mirror from the other side.

2. Strength of Glass

Strength of glass depends on modulus of rupture value of glass. In general glass is a brittle material but by adding admixtures and laminates we can make it as stronger.

3. Workability of Glass

A glass can be molded into any shape or it can be blown during melting. So, workability of glass is superior property of glass.

4. Transmittance

The visible fraction of light that passing through glass is the property of visible transmittance.

5. U value of Glass

U value represents the amount of heat transferred through glass. If a glass is said to be insulated unit, then it should have lower u value.



6. Recycle Property of Glass

Any glass can be 100% recyclable. It can also be used as raw material in construction industry.

Types of Glass and their Uses

The types of glass used in construction are:

1. Float glass
2. Shatterproof glass
3. Laminated glass
4. Extra clean glass
5. Chromatic glass
6. Tinted glass
7. Toughened glass
8. Glass blocks
9. Glass wool
10. Insulated glazed units

1. Float Glass

Float glass is made of sodium silicate and calcium silicate so, it is also called as soda lime glass. It is clear and flat so, it causes glare. These glasses are available from 2mm to 20mm thickness ranges. They have a weight range of 6 to 36 kg/m². These are used as shop fronts, public places etc.

2. Shatterproof Glass

Shatterproof glass is used for windows, skylights, floors etc. Some type of plastic polyvinyl butyral is added in its making process. So, it cannot form sharp edged pieces when it breaks.

3. Laminated Glass

Laminated glass is the combination of layers of normal glass. So, it has more weight than normal glass. It has more thickness and is UV proof and soundproof. These are used for aquariums, bridges etc.

4. Extra Clean Glass

Extra clean glass has two special properties, photocatalytic and hydrophilic. Because of these properties, it acts as stain proof and gives beautiful appearance. Maintenance is also easy.

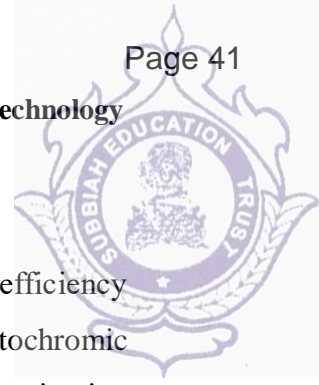

5. Chromatic Glass

Chromatic glass is used in ICU's, meeting rooms etc. it can control the transparent efficiency of glass and protects the interior from daylight. The chromatic glass may be photochromic which has light sensitive lamination, thermos-chromatic which has heat sensitive lamination and electrochromic which has electric lamination over it.

6. Tinted Glass

Tinted glass is nothing but coloured glass. A colour producing ingredients is mixed to the normal glass mix to produce coloured glass which does not affect other properties of glass. Different colour producing ingredients are tabulated below:

Coloring ion	Color
Iron oxide	Green
Sulphur	Blue
Manganese dioxide	Black
Cobalt	Blue
Chromium	Dark green
Titanium	Yellowish brown
Uranium	Yellow

7. Toughened Glass

Toughened glass is strong glass which has low visibility. It is available in all thicknesses and when it is broken it forms small granular chunks which are dangerous. This is also called as tempered glass. This type of glass is used for fire resistant doors, mobile screen protectors etc.

8. Glass Blocks

Glass block or glass bricks are manufactured from two different halves and they are pressed and annealed together while melting process of glass. These are used as architectural purpose in the construction of walls, skylights etc. They provide aesthetic appearance when light is passed through it.

9. Glass Wool

Glass wool is made of fibres of glass and acts as good insulating filler. It is fire resistant glass.

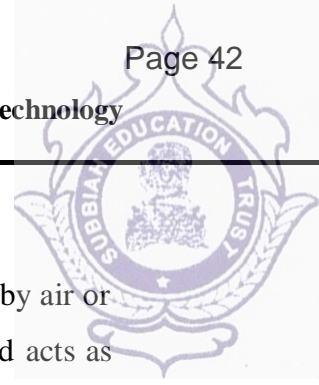

10. Insulated Glazed Units

Insulated glazed glass units contains a glass is separated into two or three layers by air or vacuum. They cannot allow heat through it because of air between the layers and acts as good insulators. These are also called as double-glazed units.

Applications of glass in construction includes

- Facades and curtain walls.
- Stair case and balcony rails.
- Bathroom cubicles
- Office/home partitioning.
- Office/home furniture etc.
- Aquariums.
- Frameless glass doors.
- Pulpits.



Fracture of Glasses

Fracture is the separation of an object or material into two or more pieces under the action of stress. The fracture of a solid usually occurs due to the development of certain displacement discontinuity surfaces within the solid. If a displacement develops perpendicular to the surface of displacement, it is called a normal tensile crack or simply a crack; if a displacement develops tangentially to the surface of displacement, it is called a shear crack, slip band, or dislocation. Brittle fractures occur with no apparent deformation before fracture; ductile fractures occur when visible deformation does occur before separation. Fracture strength or breaking strength is the stress when a specimen fails or fractures.

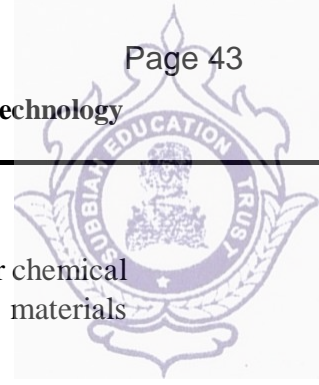

REFRACTORIES

Refractory material is a material that is resistant to decomposition of heat, pressure or chemical attack and retains strength and form temperatures. The basic refractory materials include alumina, silica, magnesia and lime.

What Are Refractories Made Of?

Refractories are produced from natural and synthetic materials, usually non-metallic, or combinations of compounds and minerals such as alumina, fireclays, bauxite, chromite, dolomite, magnesite, silicon carbide, and zirconia.



What Are Refractories Used For?

From the simple (e.g., fireplace brick linings) to the sophisticated (e.g., re-entry heat shields for the space shuttle), refractories are used to contain heat and protect processing equipment from intense temperatures. In industry, they are used to line boilers and furnaces of all types (reactors, kilns, etc.).



Let's understand refractories by an example:

Let's understand the term in more clarity by some examples. Take the example of a car which is made using a large number of materials as per the requirement. These materials mainly include copper, glass, plastics, and aluminium among others. All these materials call for extremely high temperatures when they are in the manufacturing or processing units.

For example, when the iron is converted into steel in a unit, the temperature goes up to 20000 degrees Celsius. The furnaces wherein the iron is processed always stay unaffected by the level of heat generated inside because they have a coating of refractory material. In the same way, these special coatings of refractory materials are used to process various other metals and non-metal kinds of stuff such as glass, copper, aluminium, and plastics.

Some major types of refractory materials

Refractory bricks come in a large number of shapes and sizes as per the specific requirements of an industry. Some of the most common examples of refractory materials include the following:

- Fireclay refractories
- High alumina refractories
- Silica brick
- Magnesite refractories
- Chromite refractories
- Zirconia refractories
- Insulating materials, and
- Monolithic refractories.

Based on the service conditions and temperature ranges, a large number of refractory materials are used in applications that include ovens, boilers, kilns, and conventional industrial furnaces.

Applications:

Domestic applications:

Heat-resistant materials are also used in households. Example of home applications include:

- wood-fired ovens;
- hydraulics (for the protection of central heating and water installations, as pastes for threaded connections and quick-setting mortars);
- fireplaces and stoves.

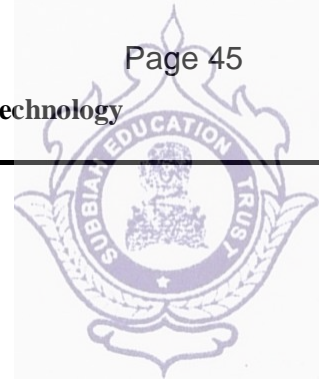

Refractories in industry:

Refractory materials are used in many different industries, including:

- ceramics industry;
- iron and steel industry;
- steel industry;
- foundry;
- aluminium and non-ferrous metal production;
- precision foundry;
- cement and lime industry;
- waste incineration plants;
- industrial boilers;
- petrochemical industry;

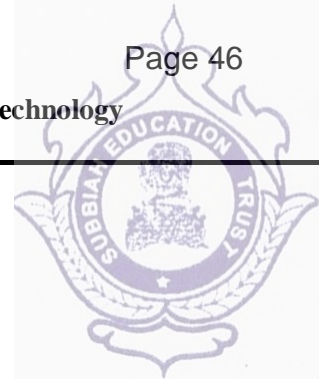

- glass industry.

Properties of Refractories:

A good refractory material should have the following properties:

1. It should be able to withstand high temperatures generated in the furnace.
2. It should be able to withstand sudden alternating heating and cooling, i.e., thermal shocks.
3. It should be able to withstand abrasion and rough usage.
4. Its contraction and expansion due to the inevitable temperature variation should be minimum possible.
5. It should be able to withstand fluxing action of the slags and the corrosive action of gases.
6. It should have good heat insulating properties.
7. It should be chemically inactive at elevated temperatures.
8. It should be impermeable to gases and liquids as far as possible.
9. If used in electric furnaces, it must have low electrical conductivity.

ALUMINUM

Aluminum (Al), also spelled aluminium (**aluminum** in North American English), chemical element, a lightweight silvery white metal of main Group 13 (IIIa, or boron group) of the periodic table. Aluminum is the most abundant metallic element in Earth's crust and the most widely used nonferrous metal.

Most Common Uses of Aluminium

Aluminium is the third most abundant metal in the Earth's crust, and the third most abundant element overall.

No other metal can compare to Aluminium when it comes to its variety of uses. Some uses of aluminium may not be immediately obvious; for example, did you know aluminium is used in the manufacturing of glass?

Aluminum is incredibly popular because it is:

- Lightweight

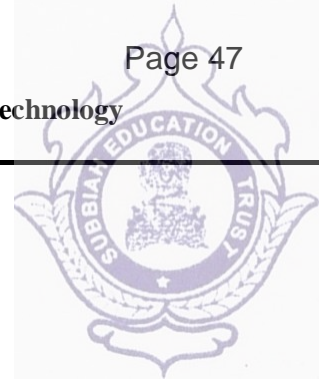

- Strong
- Resistant to corrosion
- Durable
- Ductile
- Malleable
- Conductive
- Odorless

Aluminum is also theoretically 100% recyclable with no loss of its natural properties. It also takes 5% of the energy to recycle scrap aluminum than what is used to produce new aluminum.

The Most Common Uses of Aluminum

The most common uses of aluminum include:

- Transportation
- Construction
- Electrical
- Consumer Goods

Transportation

Aluminum is used in transportation because of its unbeatable strength to weight ratio. Its lighter weight means that less force is required to move the vehicle, leading to greater fuel efficiency. Although aluminum is not the strongest metal, alloying it with other metals helps to increase its strength. Its corrosion resistance is an added bonus, eliminating the need for heavy and expensive anti-corrosion coatings.

While the auto industry still relies heavily on steel, the drive to increase fuel efficiency and reduce CO₂ emissions has led to a much wider use of aluminum. Experts predict that the average aluminum content in a car will increase by 60% by 2025.

High-speed rail systems like the Shinkansen in Japan and the Maglev in Shanghai also use aluminum. The metal allows designers to reduce the weight of the trains, cutting down on friction resistance.



A Shinkansen E6 train

Aluminum is also known as the ‘winged metal’ because it is ideal for aircraft; again, due to being light, strong and flexible. In fact, aluminum was used in the frames of Zeppelin airships before airplanes had even been invented. Today, modern aircraft use aluminum alloys throughout, from the fuselage to the cockpit instruments. Even spacecraft, such as space shuttles, contain 50% to 90% of aluminum alloys in their parts.

Construction

Buildings made with aluminum are virtually maintenance free due to aluminum’s resistance to corrosion. Aluminum is also thermally efficient, which keeps homes warm in winter and cool in summer. Add the fact that aluminum has a pleasing finish and can be curved, cut and welded to any desired shape, it allows modern architects unlimited freedom to create buildings that would be impossible to make from wood, plastic, or steel.

STEEL

Steel is a strong and versatile metal. It is an alloy consisting of iron with a small amount of carbon and occasionally other elements. The carbon directly influences the steel’s strength and durability. However, a vast array of different steels has been developed through the addition of other alloying elements such as chromium, nickel, molybdenum, and silicon. These can provide enhanced properties like abrasion resistance or corrosion resistance. There is a grade of steel for almost any application.

What Is Steel?

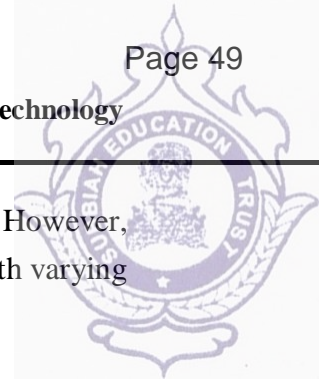

Steel, in its simplest form, is iron metal that's been alloyed with less than 2% carbon. However, many other elements can be added as well to create multiple grades of steel alloys with varying properties. Common alloying elements include chromium, manganese, and nickel.

What Is Steel Made of?

Fundamentally, steel is made of iron and carbon, but many other alloying elements also get added to create thousands of different grades of steel. Mild steel, or carbon steel, is generally more than 99% iron, containing less than 0.25% carbon, similar amounts of manganese, and traces of phosphorus and sulphur. By contrast, a common grade of stainless steel (304) has only about 70% iron with a minimum of 18% chromium and 8% nickel. Manganese, silicon, phosphorus, and of course carbon is also present in varying amounts within this type of steel. Other alloying elements for different steels include molybdenum, vanadium, and boron. Multiple grades of each type of steel exist, with variations in their composition meant to produce different characteristics.

How Are Steels Made?

Steel is made via one of two main smelting processes — either a blast furnace or an electric arc furnace.

For a blast furnace, iron ore and coke (coal that has been treated to remove volatile components) are added to the furnace, which is fired by air. Lime is also added to reduce the iron from the ore to its metallic form. This produces so-called pig iron, which is then sent to a direct oxygen furnace for the production of molten steel.

In an electric arc furnace, the iron ore is fired first by natural gas in a direct-reduction furnace. The iron metal is then sent to the electric arc furnace for steel production. Large electrodes are submerged into the furnace where electricity is used to create high-temperature arcs between the electrodes and thus melt the metal. Alloying elements are added to the electric arc furnace section.

After either process, the molten steel is then continuously cast by a hot strip mill and then rolled into different forms such as plates, bars, pipes, and others. This can be done by hot rolling or cold rolling. Other finishing processes such as tempering or annealing can also take place depending on the steel grade being produced.

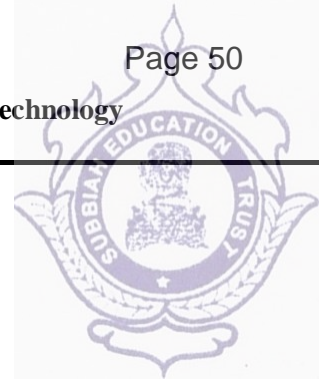

Constituent Elements	Percentage level (%)
Carbon, C	0.25 - 0.290 %
Copper, Cu	0.20 %
Iron, Fe	98.0 %
Manganese, Mn	1.03 %
Phosphorous, P	0.040 %
Silicon, Si	0.280 %
Sulfur, S	0.050 %

Characteristics of Steel

The common characteristics of steel are listed below:

1. **Strength:** Steel is a high-strength material, particularly in tension, and can be used for structural loads.
2. **Durability:** Steel is highly durable with a potential lifespan of over 100 years. It does not swell or creep, instead remaining very rigid.
3. **Versatility:** Steel is an incredibly versatile material. Its many grades can be applied to thousands of uses.
4. **Machinability:** Most steel is easily machinable, depending on the grade. Some specific grades of steel (free-cutting steels) are highly machinable.
5. **Weldability:** Most grades of steel are easily weldable, although some need specialized welding procedures.
6. **Corrosion Resistance:** Steel can be alloyed with other elements such as chromium, nickel, and molybdenum to better resist corrosion.
7. **Conductivity:** Steel generally has lower thermal and electrical conductivity compared to other metals. It can be employed as a strong and heat-resistant shielding material.
8. **Recycling:** Steel can be completely recycled, and due to its value, a large portion (>60%) of steel globally is recycled.

MARKET FORMS OF TIMBER

The timber obtained from trees is cut into suitable commercial sizes and shapes for various engineering purposes.

Following are the different forms of timber available in the market.

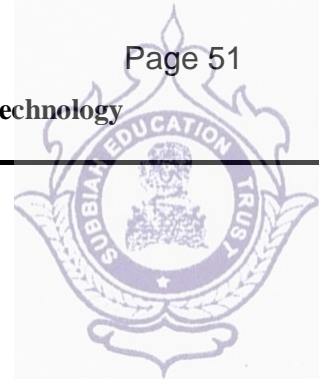

1. Log
2. Balk
3. Board
4. Batten
5. Plank
6. Pole
7. Deal
8. Scantling
9. End
10. Quartering

1. Log

The trunk of a dead tree obtained after removal of branches is called log. It can be converted into any other or required form of timber.



Fig 1: Timber Logs

2. Balk

Balk is a roughly square-shaped piece of timber obtained by removing the bark and sapwood from the timber log. The general cross-sectional dimensions of balk are greater than 50 mm x 50 mm and its length may be greater than 200 mm.

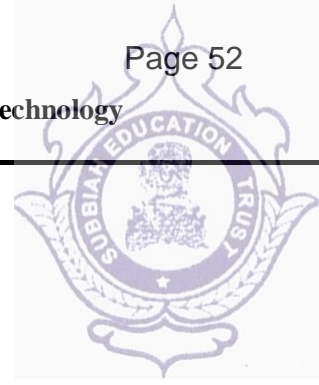

Fig 2: Balk Timber Beams

3. Batten

Batten is a piece of timber which is rectangular in its cross-section. Its thickness lies between 50 to 100 mm and breadth varies from 125 mm to 175 mm.



Fig 3: Timber Batten

4. Plank

A plank is a piece of timber whose thickness is less than 50 mm and breadth is greater than 50 mm.

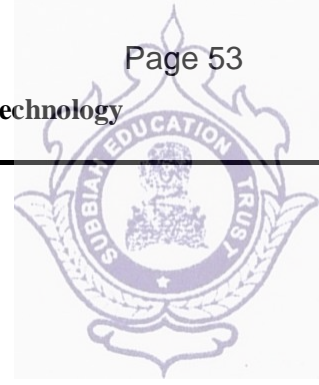

Fig 4: Timber Planks

5. Board

A timber is called board when its thickness is less than 50 mm and breadth is greater than 150 mm.



Fig 5: Timber Boards

6. Pole

A pole is a round-shaped long piece of timber. The maximum diameter of a pole is about 200 mm. It is also called as a spar.

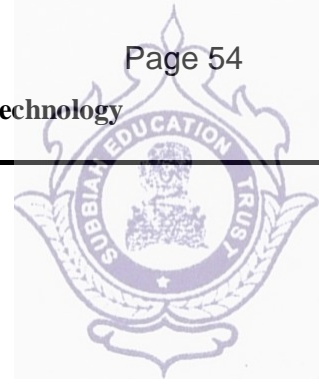

Fig 6: Timber Poles

7. Deal

A Deal is a converted form of softwood log. It is generally rectangular in cross-section. The thickness of deal varies from 50 mm to 100 mm and breadth is limited up to 250 mm.



Fig 7: Timber Deal

8. Scantling

Scantlings are the pieces of timber with nonstandard sizes. These are sawn out timber to a required size depending upon the work. The shape of the cross-section also changes according to the requirement.

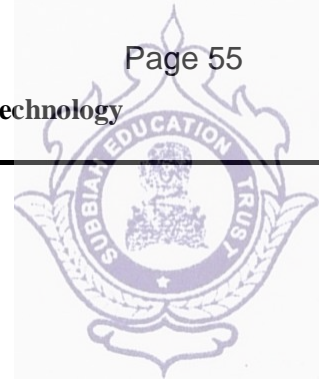

Fig 8: Timber Scantlings

9. Quartering

Quartering is a square piece of timber. Its length varies from 50mm to 150mm.



Fig 9: Timber Quartering

10. End

The short pieces of battens, deals, scantlings, poles, quartering, etc. are called as ends.

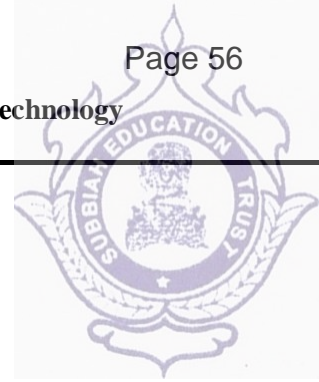
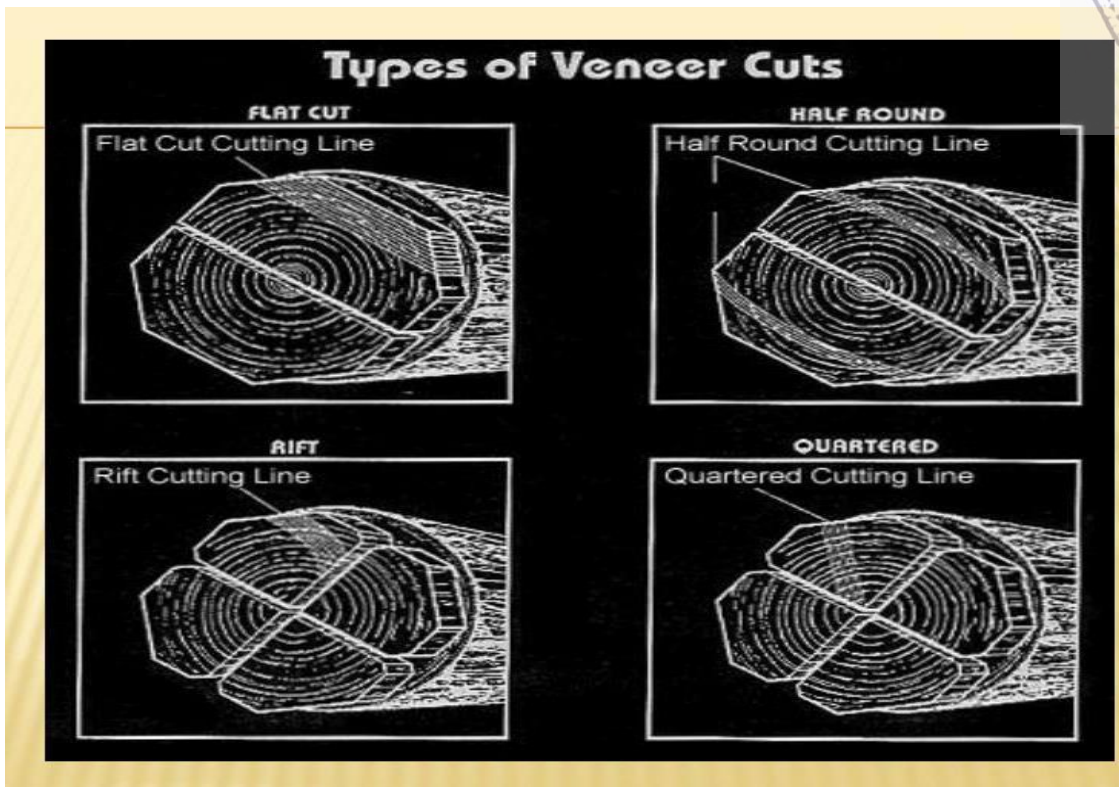

Fig 10: Timber Ends

VENEERS

- *These are thin sheets or slices of wood of superior quality.
- *The thickness of veneers vary from 0.4mm to 6mm or more.
- *The rotary cutter is used to manufacture the veneers.
- *The Indian timbers which are suitable for veneers are mahogany, rosewood, teak etc..
- *The process of preparing a sheet of veneers is known as veneering.
- *The veneers are used to produce plywoods, batten boards and lamin boards.

	<p>Rotary Cut</p> <p>The log is centered on a lathe and turned against a broad cutting knife set into the log at a slight angle.</p>	
	<p>Quarter Slicing</p> <p>The slicing is made perpendicular to the annual growth rings of the tree. This creates a straight grain appearance.</p>	
	<p>Lengthwise Slicing</p> <p>This is done from a board of flat sawn lumber rather than from a log. A variegated figure is created with this slice.</p>	



Applications of Engineered Wood Veneers



Wood veneers are a highly versatile surfacing material that can be glued onto various types of core surfaces to produce decorative panels and furniture. When used with care and creativity, wood veneers deliver a distinct appeal that is simply a cut above the rest. Leading engineered veneer suppliers offer a wide range of options with various textures and grains to complement different decor and functional needs.

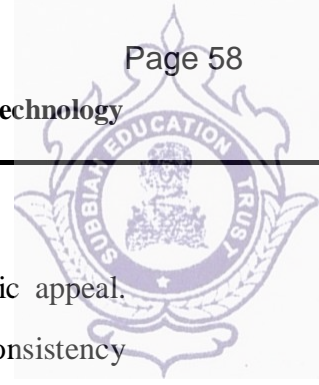

Wall Panels

Engineered wood veneer can be used on walls panels to increase their aesthetic appeal. Reconstructed from different species of wood, engineered veneer sheets provide consistency in grain and color. Besides being available in a wide range of design, color and texture, engineered veneer is also remarkably durable and moisture resistant, which makes it an ideal choice for wood panels.

Ceilings and Walls

Engineered veneer sheets are the future of environmentally green, high-end veneer core. Ceilings and walls adorned with engineered wood veneer sheets help customize the interiors of your property to fit the style and decor. Whether you want a minimalistic or luxurious ambience, wood veneers can help you manifest your vision to perfection.

Furniture

Chairs, tables, dressers and other furniture pieces can be easily given a new and unique appeal with engineered wood veneers. You can take your pick from a wide variety of wood veneers that can be used to create countless patterns and arrangements. This allows you to explore endless design possibilities, and achieve the desired appeal with ease.

Cabinets

Engineered veneers on cabinets can provide the desired aesthetic appeal. With engineered veneer, it is easy to create and apply patterns that make your cabinet surfaces stand out. With wood veneers, engineered oak veneers and other, more exotic wood types available, the cabinets can look truly unique and stylish.

Artwork

Engineered wood veneers are quite agile and easy to work with, which makes them ideal for decorative artwork. From creating wooden instruments to decorating your favorite collector's items, wood veneers can be a great way to enjoy the artwork of any scope and size.

Wrap Up

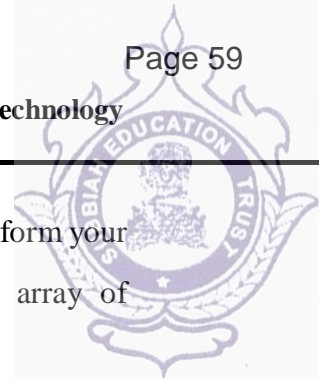

Engineered wood veneer sheets, coupled with fine craftsmanship and skills, can transform your property. From ceilings to furniture, engineered wood veneer sheets have an array of applications that can help you protect and beautify your living spaces.

PLYWOOD

*The meaning of term “ply” is a thin layer.

*Several layers of veneers of wood glued together and a thick plywood is prepared.

*This technique that may have been used in some form for thousands of years.

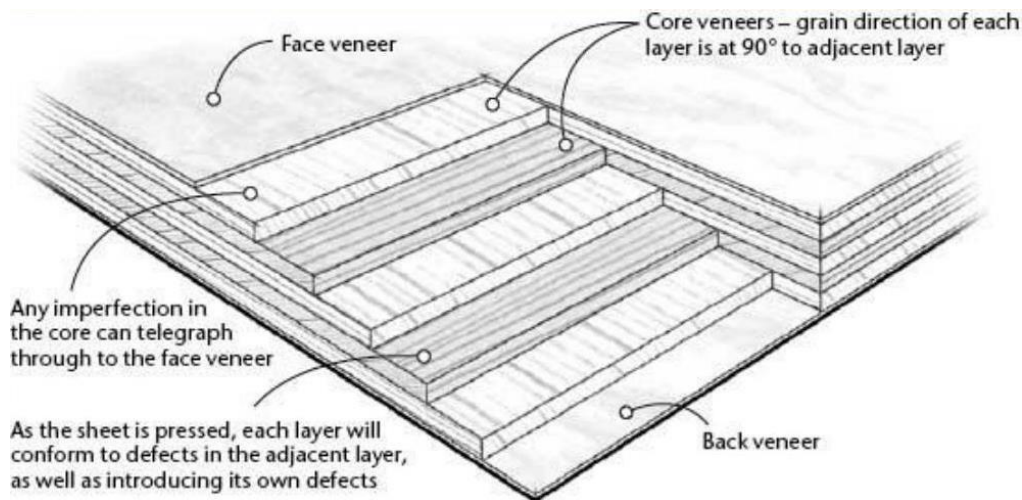

Advantages Of Plywood

1. Better appearance.
2. Easily workable, cut in any shape.
3. Elastic material, not affected by changes in atmosphere.
4. Light weight and greater strength.
5. Highly resistant to cracking, spalling as it has great stiffness and rigidity.
6. Available in large size.

Uses Of Plywood

The plywood is used for various purpose such as ceiling, doors, furniture, partitions, paneling walls, packing cases, railway coaches, form work for concrete.

Applications Of Plywood

As noted, plywood has inherently good strength properties that can be engineered for certain uses. In structural terms, plywood can be used for partitions, floors, ceilings and sheathing. It is also used for decorative purposes both in exterior positions, such as

cladding and doors, and internally as cabinets, shelves and furniture. The highest specification of plywood is used for marine environments, such as boats and docks.

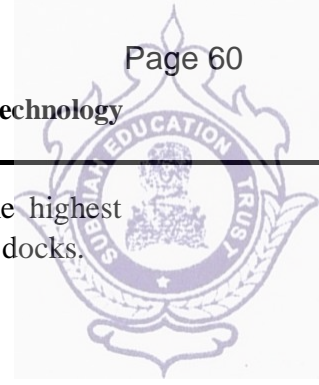

UNIT III

CONSTRUCTION PRACTICES & SERVICE REQUIREMENTS

BRICK MASONRY

Definition

Brick masonry is a highly durable form of construction. It is built by placing bricks in mortar in a systematic manner to construct solid mass that withstand exerted loads. There are several types of bricks and number of mortars which can be used to construct brick masonry. The bond in brick masonry, which adheres bricks together, is produced by filling joints between bricks with suitable mortar. Special cautions shall be practiced while mortar is mixed and placed since it greatly affects the performance and durability of masonry structure.

Types of Brick Masonry Work

1. Brick Work in Mud

- The mud is used to fill up various joints brick masonry work.
- Thickness of the mortar joint is 12 mm.
- it is the cheapest type of brick masonry
- employed for construction of walls with maximum height of 4 m.



Fig. 1: Brick work in mud

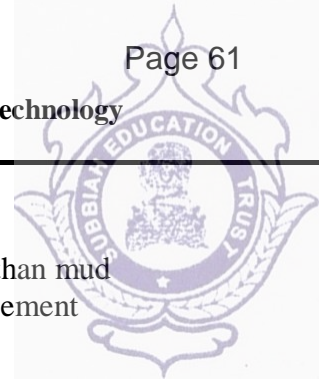

2. Brick Work in Cement

This type of brick masonry is construction by laying bricks in cement mortar rather than mud which is used in brick work in mud. There are three major classes of brick work in cement which are summarized in Table 1.

Table 1 Different classes of brick work in cement and their descriptions

Classes	Descriptions
First Class	<ol style="list-style-type: none"> 1. Cement of lime mortar is used, 2. The surface and edges of bricks are sharp, 3. And the thickness of mortar joints doesn't exceed 10mm
Second Class	<ol style="list-style-type: none"> 1. Ground molded bricks are used, 2. Bricks are rough and shape is slightly irregular, 3. The thickness of mortar doesn't exceed 12mm
Third Class	<ol style="list-style-type: none"> 1. Bricks are not hard, rough surface with distorted shape, 2. Used for temporary structures, 3. Used in places where rainfall is not heavy.

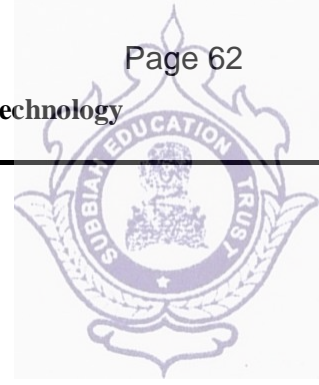

Fig. 2: Brick work in cement

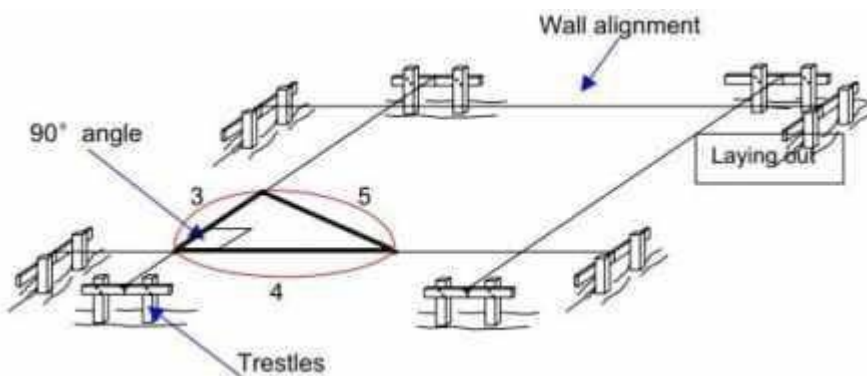

Fig. 4: Setting out layout of masonry structure

1. Trace of building axis and wall alignment using gypsum powder, chalk, or similar, marking the trenches for foundation.
2. After that, install foundation wall, cure foundation for minimum two days before beginning of brick masonry construction.
3. Distribute bricks in several stacks along project site to cut time and effort later.
4. Wet bricks few hours prior to the work. Not only does this avoid absorbing too much water from mortar but also improve adherence of bricks and mortar.

Brick Masonry Construction Procedure

1. Initially, mix the mortar with water and blend it until a smooth and plastic mortar is produced.

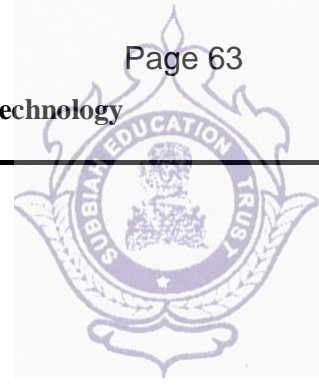

Fig. 5: Mortar Preparation

2. After that, place the mortar on foundation line evenly using trowel (25mm thickness and one brick wide is recommended for laid mortar).
3. Then, lay the first course of stretcher bricks in the mortar. Start with second brick, apply mortar to the head joint end of each brick, after that shove the bricks into place firmly so that the mortar is squeezed out of all side of the joints.



Fig. 6: laying bricks

4. Utilize a level to examine the course for correct height. ensure that bricks are plumb and level.

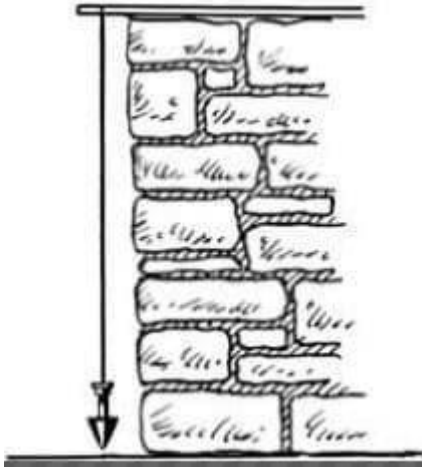
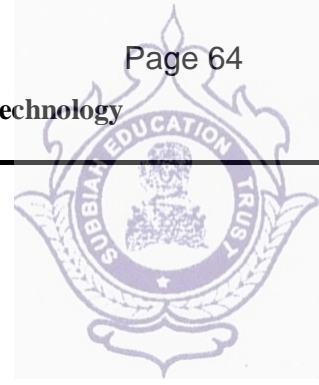

Fig. 7: Plumb line of brick masonry



Fig. 8: Checking level of brick masonry

5. Place another mortar line alongside the first course, then begin laying the second course.
6. Use the two half bricks to begin the second to ensure that the first two courses are staggered for structural purposes.
7. To finish the second course of the lead, lay three header bricks and make sure that they are plumb and level.
8. The third and fifth courses consists of stretchers similar to the first course. The fourth course begins with single header, followed by stretchers. Use the level to make sure that the lead is true on each course. Lastly, this pattern of brick laying is used till the target height is reached.

CAVITY WALL

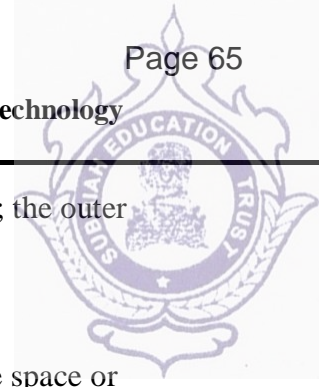

A cavity wall is **made up of two walls with a gap in between**, known as the cavity; the outer leaf is usually made of brick, and the inner layer of brick or concrete block.

What is a Cavity Wall?

Cavity wall is constructed with two separate walls for single wall purpose with some space or cavity between them. These two separate walls are called as leaves of cavity wall. The inner wall is called as internal leaf and outer wall is called as external leaf. Cavity wall is also

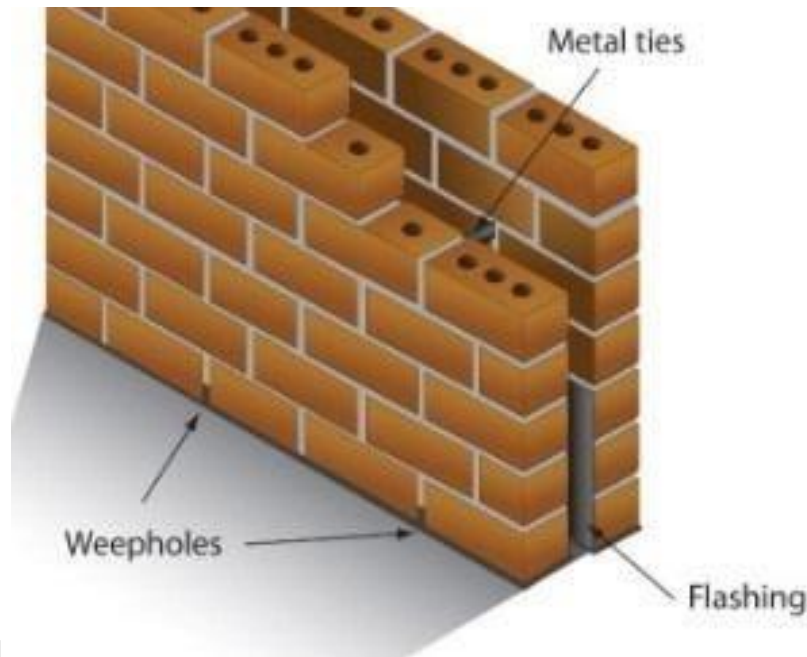

called as Hollow wall.

For non-load bearing cavity wall, two leaves are of equal thickness or sometimes internal leaf with more thickness is provided. The cavity size should be in between 4 to 10cm. The internal and external leaves should have at least 10 mm thickness. The two leaves are interconnected by metal ties or links as shown in above figure.

Construction of Cavity Walls

In general, cavity wall doesn't require any footings under it, just a strong concrete base is provided on which cavity wall is constructed centrally. Two leaves are constructed like normal masonry, but minimum cavity must be provided in between them. The cavity may be filled with lean concrete with some slope at top up to few centimeters above ground level as shown below.

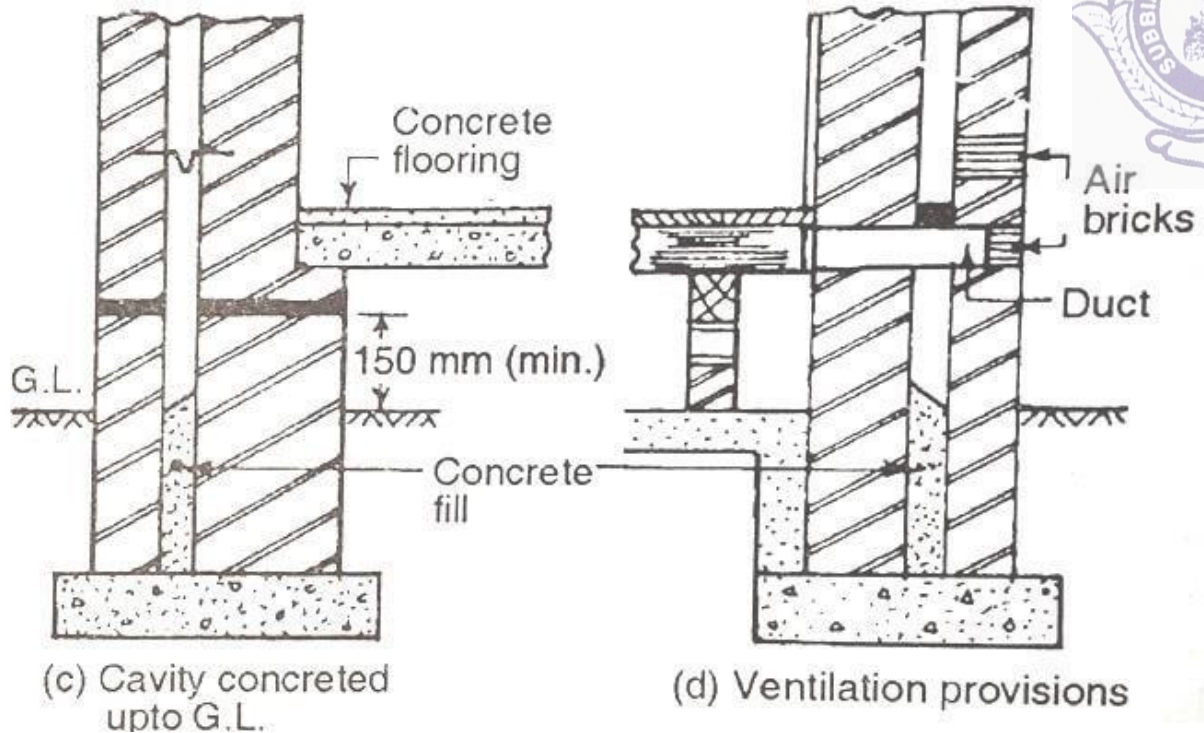
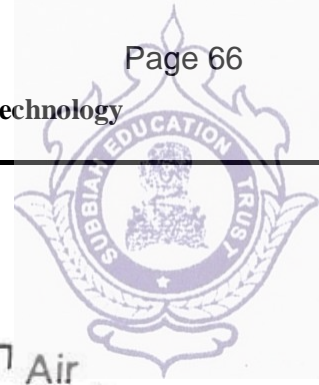

Weep holes are provided for outer leaf at bottom with an interval of 1 m. Normal bricks are used for inner leaf and facing bricks are used for outer leaf. Different masonry is also used for cavity wall leaves. The leaves are connected by metal ties or wall ties, which are generally made of steel and are rust proof. The maximum horizontal spacing of wall ties is 900mm and maximum vertical spacing is 450mm. The wall ties are provided in such a way that they do not carry any moisture from outer leaf to inner leaf. Different shapes of wall ties are shown in below figure.



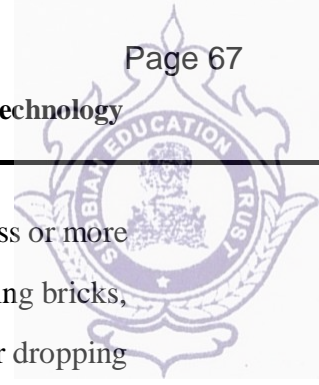

For half brick thickness leaves, stretcher bond is provided. And for one brick thickness or more thickness, English bond or Flemish bonds type constructions are provided. While laying bricks, care should be taken without filling the cavity with cement mortar. To prevent mortar dropping in cavity, wooden battens are provided in the cavity with suitable dimensions. These battens are supported on wall ties and whenever the height of next wall tie location is reached, then the battens are removed using wires or ropes and wall ties are provided.



Two leaves should be constructed simultaneously. Spacing should be uniform and it is attained by predetermining the location of wall ties. Damp proof course is provided for two leaves separately. In case of doors and windows, weep holes are provided above the damp proof course.

Advantages of Cavity Walls

Following are the advantages of cavity wall when compared to solid walls.

- Cavity walls give better thermal insulation than solid walls. It is because of the space provided between two leaves of cavity walls is full of air and reduces heat transmission into the building from outside.
- Economically they are cheaper than solid walls.
- Moisture content in outer atmosphere is does not allowed to enter because of hollow space between leaves. So, they also prevent dampness.
- They also act as good sound insulators.

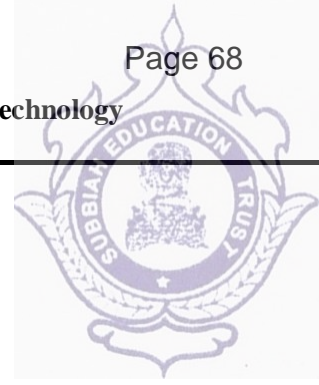

- They also reduce the weights on foundation because of their lesser thickness.
- Outer Efflorescence is also prevented.

COFFERDAM

A cofferdam is an enclosure built within a body of water to allow the enclosed area to be pumped out or drained. This pumping creates a dry working environment so that the work can be carried out safely. Cofferdams are commonly used for construction or repair of permanent dams, oil platforms, bridge piers, etc., built within water.

These cofferdams are usually welded steel structures, with components consisting of sheet piles, Wales, and cross braces. Such structures are usually dismantled after the construction work is completed.

Types of Cofferdams

Considering the material used in their construction, cofferdams may be divided into the following categories.

- Earthen cofferdam
- Rockfill cofferdam
- Single-walled cofferdam
- Double-walled cofferdam
- Braced cofferdam
- Cellular cofferdam (Circular or diaphragm type)

Earthen Cofferdam

Earthen cofferdams are constructed at the place where the height of the water is less say 3m and the current velocity is low. These dams are built using the local available material such as clay, fine sand or even soil. The height of the dam is kept 1m more than that of max water level. Freeboard of the dam or the top of the dam is kept 1m so that the water doesn't enter the other side even when waves arise. The slope is usually given but 1:1 or 1:2. The slope of the water side is pitched with rubble stones so the water action doesn't score the embankment. Even sheet piles are driven in the centre of the dam to resist water seepage. After the

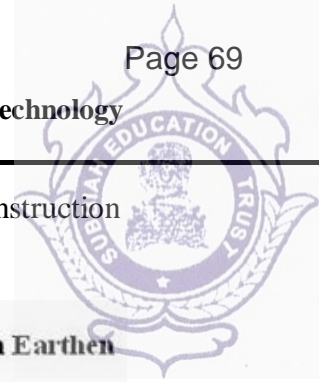

construction of earthen cofferdam, the water from the other site is pumped out and construction is executed.

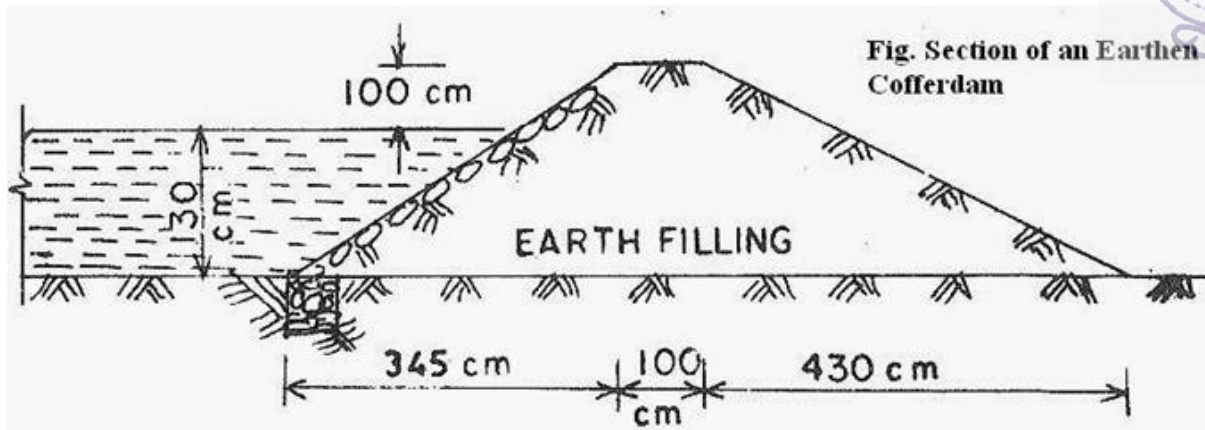

Fig: Cross-Section of an Earthen Cofferdam

Rockfill Cofferdam

Rock-fill cofferdams are better than that of earthen dams. These dams are preferred when the rock is available easily at the construction site. These dams are very pervious, to prevent water from seeping an impervious membrane of soil is provided in the dam. The height of the dam is can be up to 3m. The slope can be maintained at 1:1.5 to 1:1.25. The slope on the water side is pitched so as to protect dam from wave action.

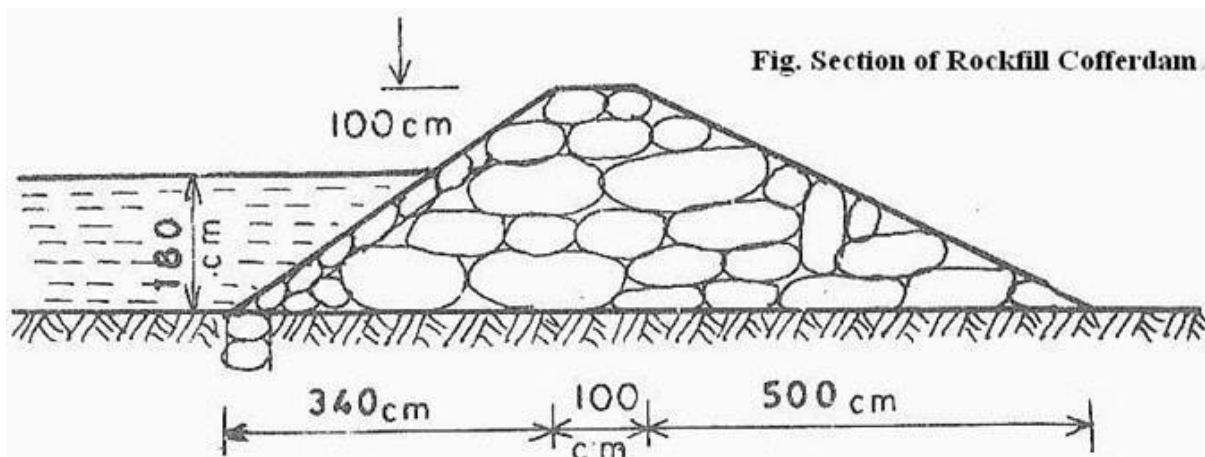
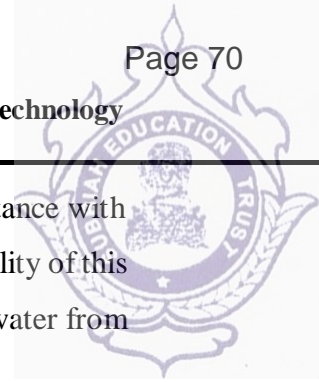

Fig: Cross-Section of Rockfill Cofferdam

Single-Walled Cofferdam

This type of cofferdam is preferred when the depth of the water is more than 6m and area of construction is less. Usually this is used in construction of bridges. Wooden or timber sheets are driven into the river bed on the perimeter of the area of construction. On the inside steel or



iron sheets are driven into the river bed. These inside sheets are placed at equal distance with the help of wales which are bolted to both sheets for either side. To improve the stability of this types of dams, half-filled bags of sand are placed on the both side of the walls. The water from the inside is pumped out and the construction process is undertaken.

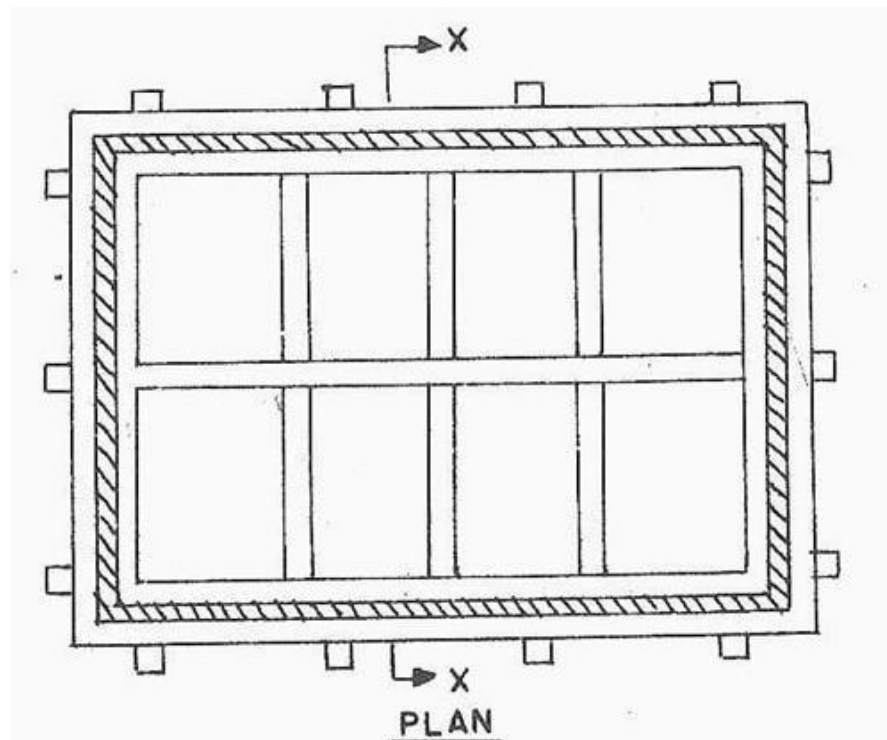
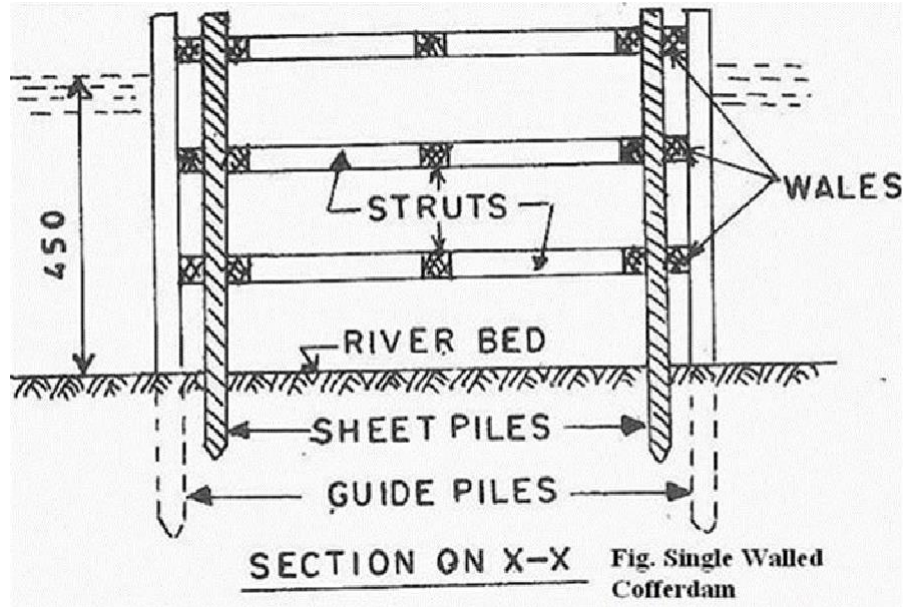

Fig: Construction Details of Single Walled Cofferdam

Double-Walled Cofferdam

Double-walled types of cofferdams are used when the area of construction site is large and depth of water is high. In this place use of single walled cofferdam becomes uneconomical as the supports are to be increased. So double walled cofferdam is used. The difference in one wall and double wall dam is that it has two walls instead of one wall for extra stability. This type of dams can hold water up to 12m high. Two piles are driven inside the water bed with a space in between and attached each other with wales with bolted connection. As the water depth increases the space between the walls increases. The space between the walls are filled with soil. To prevent the leakage from the ground below, the sheet piles are driven to a good depth in the bed.

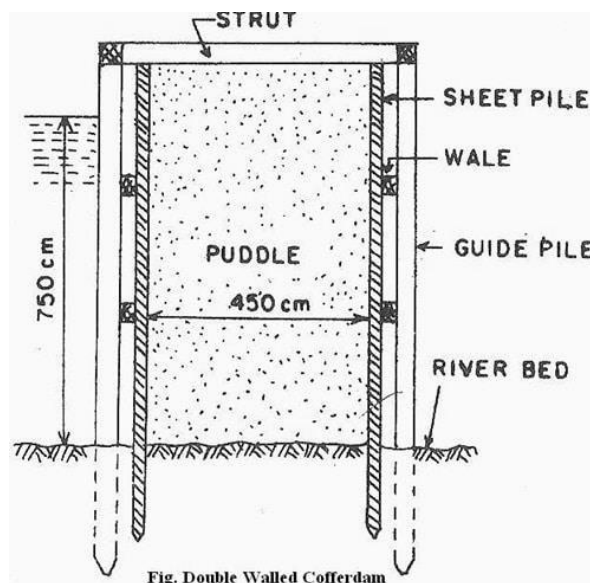

Fig: Construction Details of Single Walled Cofferdam

Braced Cofferdam

When it's difficult to drive piles inside the bed in the water, then this type of cofferdam is used. In braced cofferdam two piles are driven into the bed and they are laterally supported with the help of wooden cribs. The framework of the cofferdam (made from logs of wood) is prepared on ground and then floated to the site where the cofferdam is to be constructed. The layers of sand and the other loose material overlying the impervious hard bed is dredged out. Crib is then sunk to the position; the bottom of each crib is given a shape to fit in the variation in the surface of bedrock. After the pit is dewatered, the structure is concreted. When concreting has been completed above the water level, the cofferdam is removed.

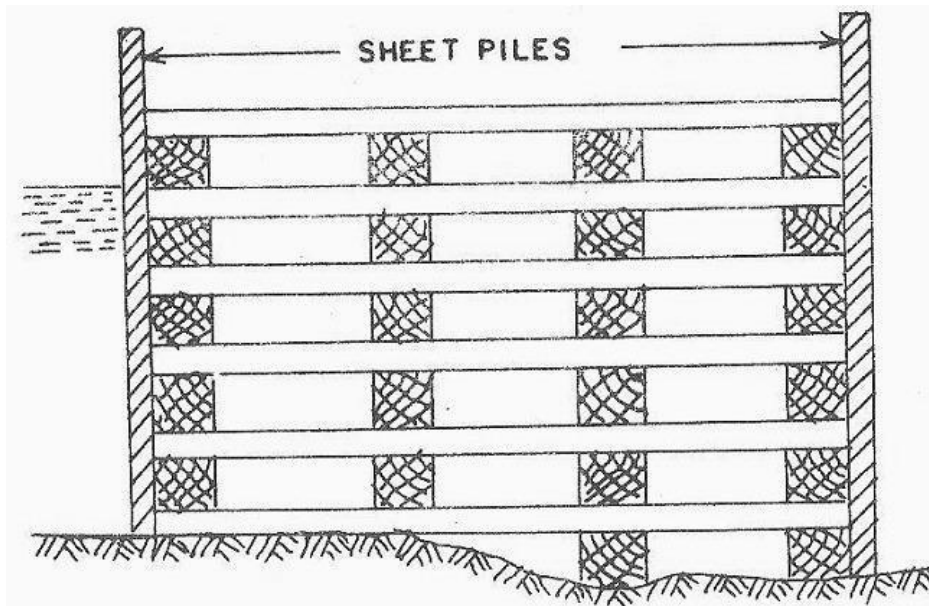
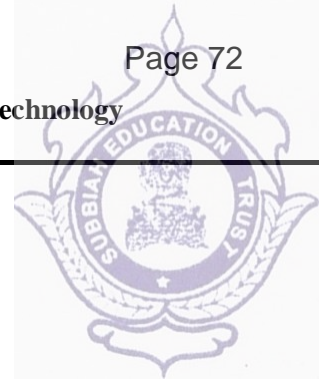

Fig: Braced Cofferdam Construction Details

Cellular Cofferdam

When the water layer is more than 20m, common types of cofferdams are uneconomical to use. In this situation cellular cofferdams are used. This type of dam is used in construction of dams, etc. Cellular cofferdam is made by driving straight web steel sheet piles, arranged to form a series of interconnected cells. The cells are constructed in various shapes and styles to suit the requirements of site. Finally, the cells are filled with clay, sand or gravel to make them stable against the various forces to which they are likely to be subjected to.

CONSTRUCTION JOINT

The Construction Joint in concrete used to prevent any crack during its life period. Concrete has the property of expansion and contraction due to temperature changes, which is resulting in a change in the volume of concrete. This change in the volume of concrete can be a cause of concrete cracking. Therefore, to prevent concrete crack construction joints are provided in concrete.

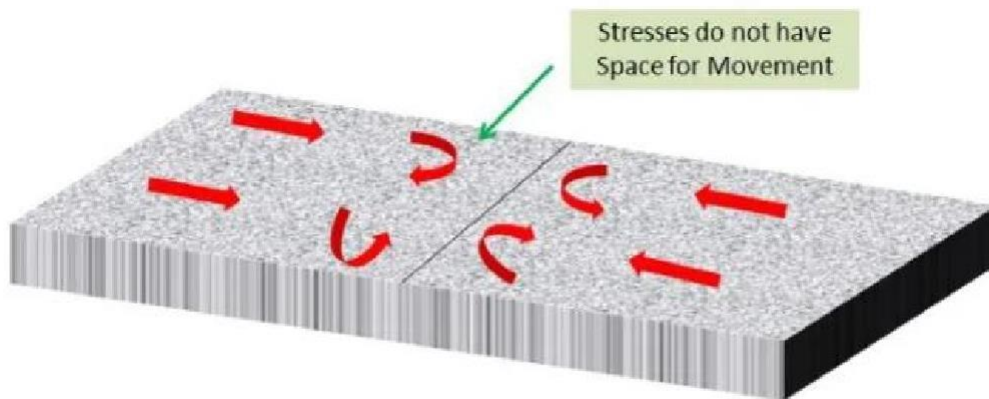
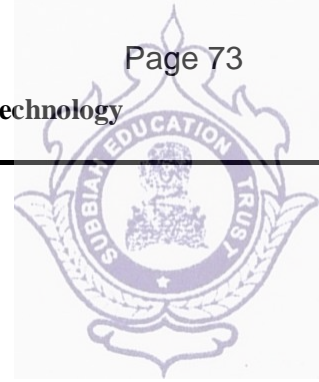

Construction Joints in Concrete

Construction joint is essential if the size or length of concrete members exceeds some specified limit.

Generally, for short-length concrete member construction joints are not required, because for expansion and contraction of concrete there is the end of concrete is too close. But when the length of the concrete member has exceeded a certain limit there is no endpoint where this volume change can take place.

In such a case, the concrete member will crack.

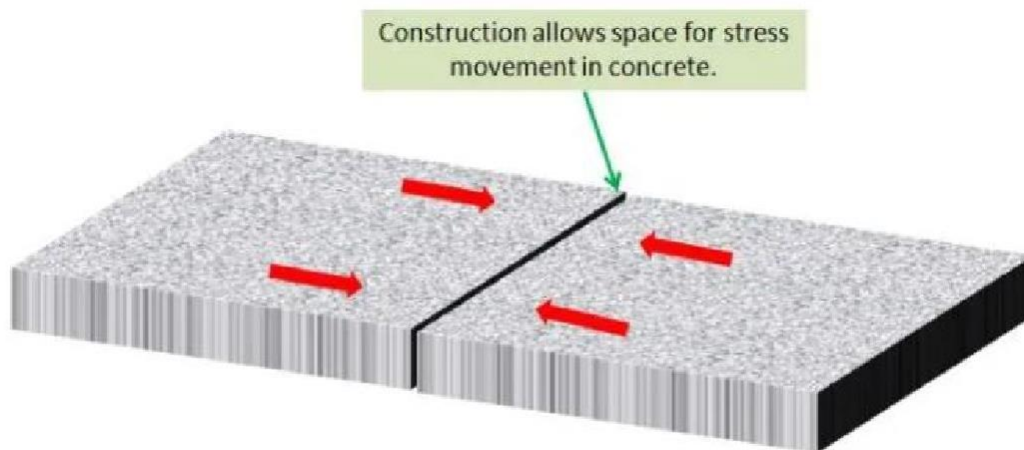

Construction Joints in Concrete

The following are the common concrete joint,

1. Concrete Construction joints
2. Expansion joints
3. Contraction joints

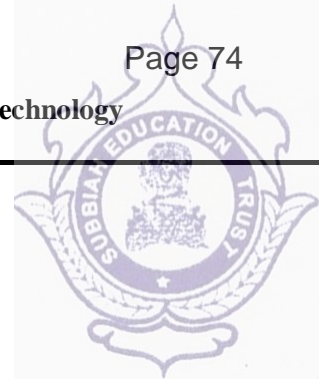

4. Isolation joints
5. Decorative concrete joints

1. Concrete Construction Joints

Construction joints are generally placed in the concrete slab to determine the extent of the individual placements. It is generally in conformity with a predetermined joint layout.

Construction joints are designed in order to allow the displacement between each (both) side of the slab but, they also transfer the flexural stresses produced in the slab by the external loads at the same time.

Construction joints allow only the horizontal displacement which is right-angled to the joint surface that is normally caused by the thermal or shrinkage movement. Vertical or rotational displacement is not allowed by the joint at the same time.

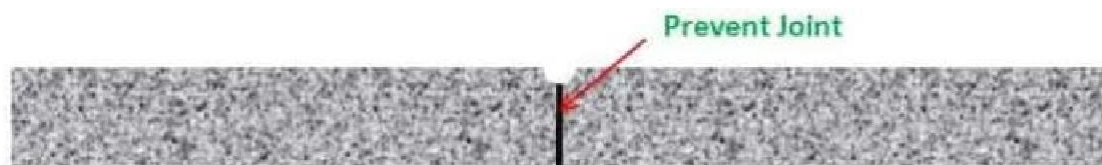

1. Butt Type Construction Joints

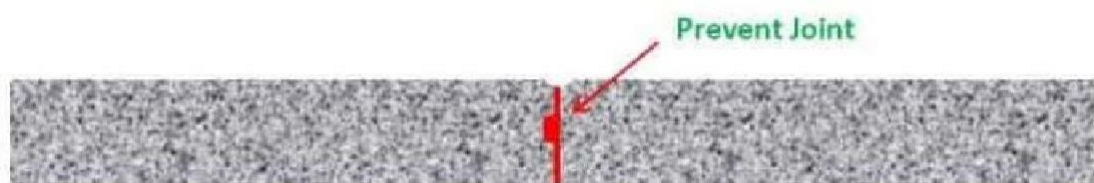

2. Tongue & Groove Construction Joints

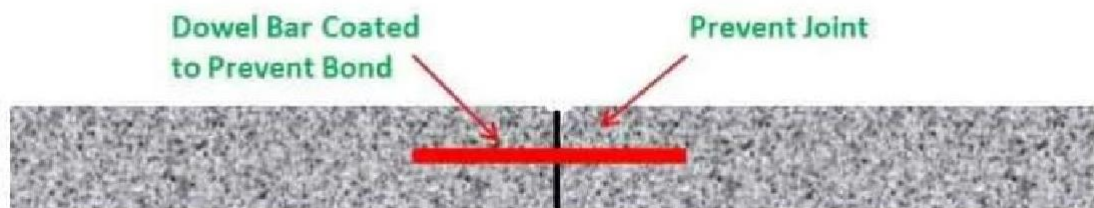

3. Butt Type Construction Joints with Dowel Bar

Types of Construction Joint

2. Expansion Joints

Sometime due to many reasons volume of the concrete is change. For these reasons, we provide the joint to relieve the stress. The building that length is more than 45m provided one or more expansion joints. In India, it recommended in the building that the c/c distance is 30m.

Expansion joint means a GAP is provided between the parts of the building.

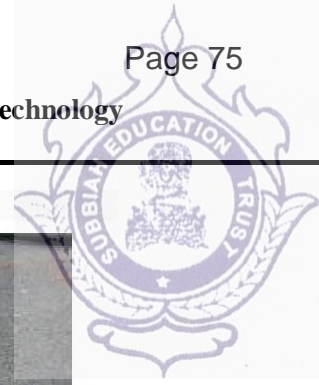

Expansion Joint in Pavement

3. Contraction Joints

Contraction joint which is made in the concrete slab with help of the sawed or it should be created or groove which creates a weakened vertical plane. Cracks in the slab due to the dimensional changes are resisting by the contraction joint.

Due to the unregulated cracks can grow or the water is infiltrated in the base, sub-base or subgrade of pavement creates other types of distress in the pavement.



Contraction Joint in Concrete

It is the most common type of joint in pavements, so the term “joint” refers to a contraction joint. Contraction joints are defined by their spacing and their method of load transfer. In the

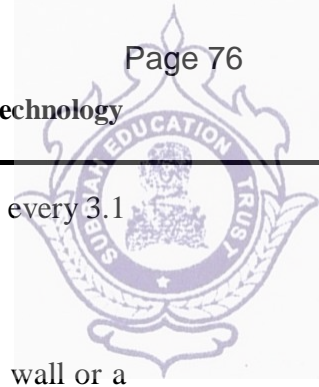

slab, contraction is provided at the $1/4 - 1/3$ the depth of the slab or typically spaced every 3.1 to 15m.

4. Isolation joints

Isolation joint is used for a special purpose it completely isolates the slab from the wall or a column or drains pipes. The walls or the columns that have their own footing or deeper than the slab subgrade are not easily joint to move the same way as a slab does it shrinks or expands due to drying or temperature changes or as the subgrade compresses a little.



Isolation Joint

If the slab is connected to these types of walls or columns or the drain pipes as they contract or settle there will be resisted but the cracks shown on the slab.

5. Decorative Concrete Joints

In decorative concrete construction of joints is requires a little more planning and execution. The decorative stamping is not sunk deep in the concrete slab because the stability of the slab is needed.

The joints are generally penetrated $1/4^{\text{th}}$ of the surface. So, the cracks are carefully controlled. We just need to cut the concrete along with the pattern of the stamped design so the joints are not visible from the surface.



Decorative Concrete Joints

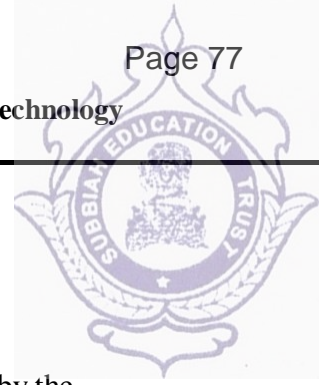

DAMP-PROOF COURSE

A damp-proof course is commonly abbreviated as the DPC.

It is a barrier or obstruction that is primarily designed to prevent the moisture rising by the capillary action.

The capillary action through which the moisture rises is known as the rising damp.

In other words, a damp-proof course can be defined as the layer of material that is used to prevent the penetration or passage of moisture inside the structure through the floors, walls or roofs.

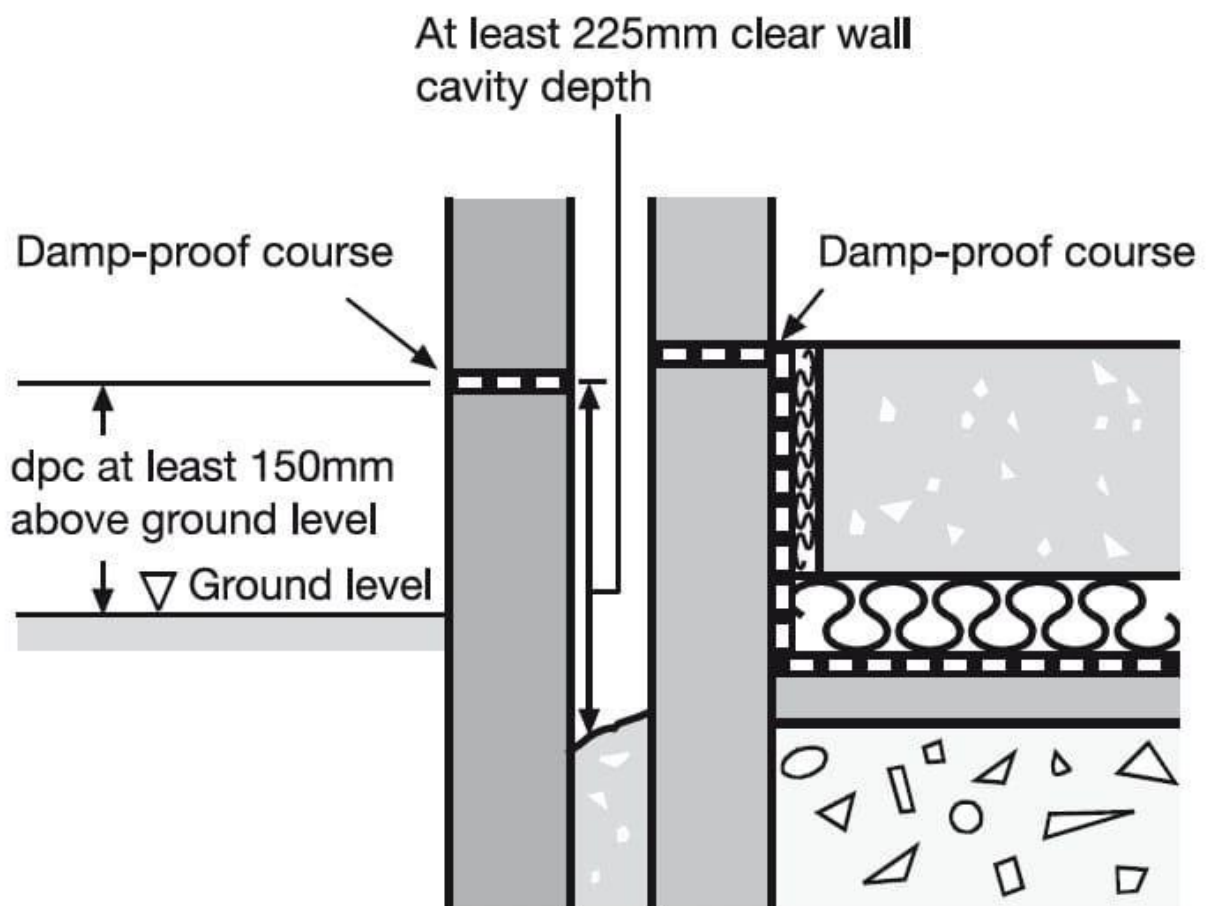

It is commonly applied at the basement level of the structure and thus prevents the passage of moisture through the floors and the walls.

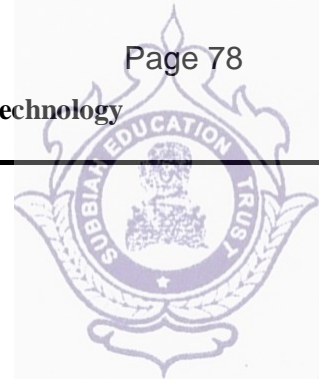

Purposes Of the Damp Proof Course

The major purposes of the damp proof course can be listed as follows:

- a. To prevent the movement of moisture in the structure.
- b. To prevent the breeding of mosquitoes, growth of termites and other unhealthy conditions that may arise due to dampness.
- c. To prevent the development of unpleasant patches on the walls of the building.
- d. To protect the painted surfaces from dampness.
- e. To prevent the softening as well as crumbling of the plasters.
- f. To prevent the deterioration of timber fittings such as doors and windows by warping due to the contact with dampness for a subsequent period.
- g. To protect the floors from the detrimental effect of moisture movement such as reduction of adhesion, loosening of flooring etc.
- h. To prevent the pipes and fittings from corrosion by the ingress of moisture.

Desirable Properties of Materials Used for Damp Proof Course

The desirable properties of the materials used for the damp proof course can be listed as follows:

- a. The material used for the damp proof course must be impervious i.e. it must prevent the passage of moisture through it.
- b. The material must be strong as well as durable. It must be strong enough to resist both the imposed live loads and dead loads without failure.
- c. It must be dimensionally stable.
- d. It must be free from harmful deliquescent salts such as chlorides, nitrates and sulphates.

Materials Used for Damp Proof Course

Various types of materials are available for the construction of the damp proof course.

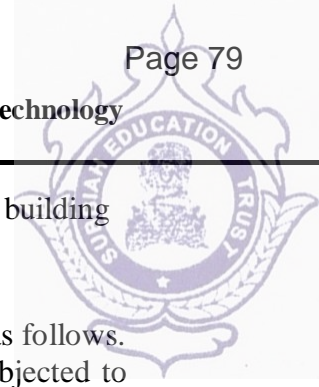

These materials are generally selected based on the type of structural element of the building and the type of damp proofing required.

The most common types of materials used for the damp proof course can be listed as follows. These are the materials that do not deform their shape and do not crack when subjected to loading. Some of the flexible materials that are used for the damp proof course can be listed as follows:

i. Mastic Asphalt/ Bitumen Asphalt

The mastic asphalt mainly consists of bitumen that is mixed with the fine sand in the hot state to form an impervious mass.

When the mixture is hot, the consistency is such that it allows the mixture to spread evenly to a depth of about 2.5cm to 5cm.

Upon cooling, the mixture sets.

However, special care must be taken while laying the mastic asphalt as the damp proof course.

ii. Hot Laid Bitumen

The hot laid bitumen is mostly used on a bedding of cement concrete or mortar.

It is usually laid in two consecutive layers at the rate of 1.75kg/m² of the area.

iii. Bitumen Felts (Sheets)

The bitumen felts consist of a 6mm thick sheet of bitumen prepared in rolls and having a width equal to that of a brick wall.

iv. Metal Sheets

Metal Sheets are used throughout the thickness of the walls to prevent dampness.

Mostly, metal sheets of aluminum, lead and copper are used for such purposes.

These sheets are coated with asphalt such that the thickness of the sheet is equal to or greater than 3mm.

The metal sheets of lead must be laid over the lime mortar instead of cement mortar because the chemical reaction between cement and lead may occur.

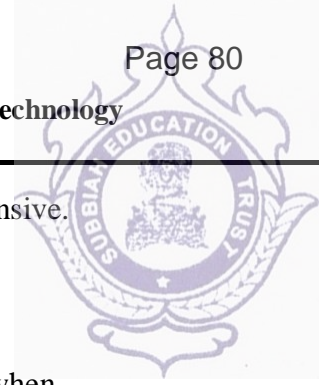

The metal sheets are highly effective in preventing dampness but are relatively expensive.

Rigid materials for DPC

The rigid materials are not capable of withstanding the traverse stresses and cracks when subjected to extreme loading. Some of the rigid materials used in DPC are:

a. Rich Concrete

Rich Concrete is the most commonly used material in DPC.

Usually, rich concrete in the proportion 1:2:4 that is painted with two relative coats of hot bitumen is used for the horizontal damp proof course.

It is suitable for the portions of the building or structure that are not subjected to excessive dampness. It prevents the ingress of moisture by the capillary action.

b. Mortar

Mortar is extensively used for vertical damp proof courses.

Usually, a 2cm thick rich cement layer and sand mortar (1:3) is applied on the inner surface of the external wall.

After laying the mortar, the surface is painted with hot bitumen in two coats.

c. Bricks

Bricks are used when effective damp proofing is required on a comparatively low budget.

Mostly, the dense bricks and the over burnt bricks are used for this purpose.

The bricks are laid in rich cement and sand mortar of a ratio of 1:3.

It is used for the DPC in the cheap type of construction.

d. Stones and Slates

Two layers of stones are laid in lime, cement and sand mortar (1 lime :1 cement: 6 sand) which acts as DPC. In some cases, the slate and the stone slabs can also be laid in cement sand mortar. It is mostly used where quality stones are found easily at a cheap rate.

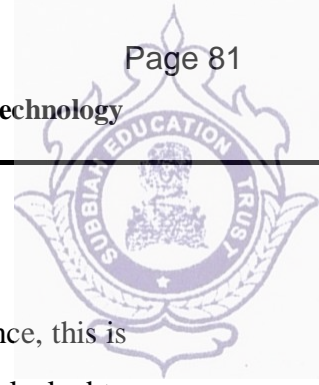

DIAPHRAGM WALL

A diaphragm wall forms a rectangular section constructed in-situ under the soil. Hence, this is an underground concrete wall. These walls are constructed panel-by-panel each interlocked to ensure structural stability and water tightness.

The diaphragm walls can have a thickness ranging from 60cm to 150cm with a width of 2.0 to 3.5m. The diaphragm walls can be constructed up to a depth of 60m.

How to construct a Diaphragm Wall?

The construction sequence mainly has three steps:

1. Construction of Guide Wall
2. Excavation of the panel
3. Wall Concreting

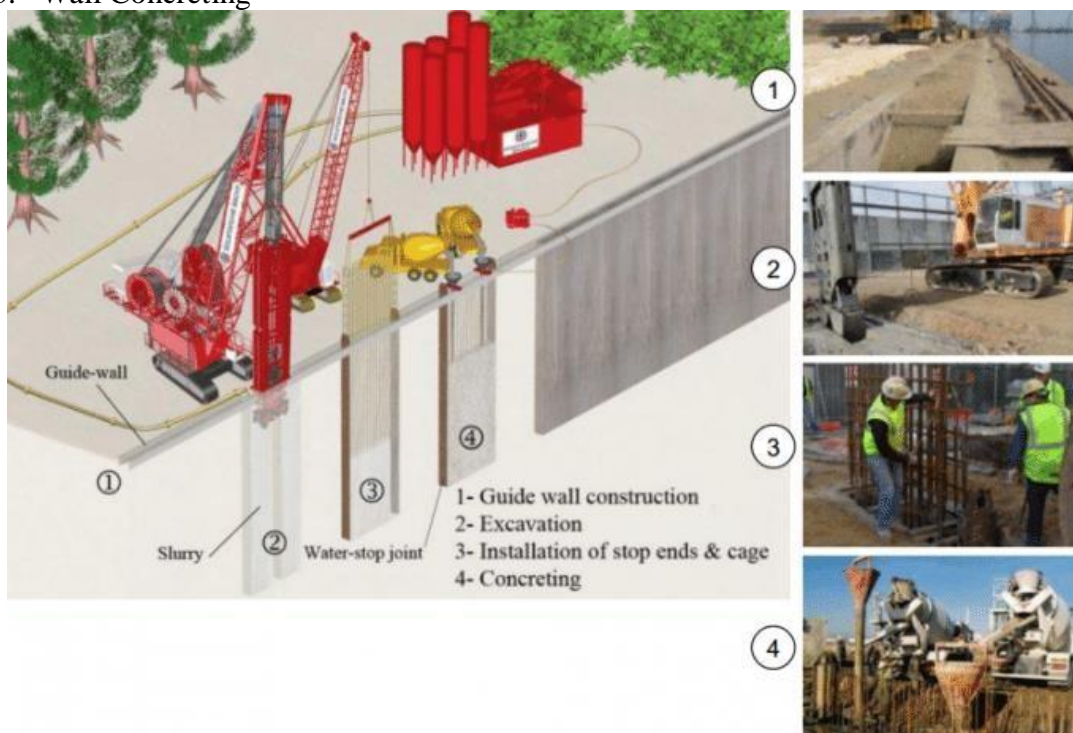

Fig.1. Construction Stages of Diaphragm Wall

1. Construction of Guide Wall

Guide walls are two temporary parallel beams constructed along the side of the wall in order to guide the excavation tool and stabilise the top portion. The implementation of guide walls prior to diaphragm-wall construction helps to maintain the horizontal alignment and continuity of the diaphragm walls constructed. Guide walls also:

- Avoid Soil collapse
- Help mark the panel positions
- Support the reinforcement steel cages

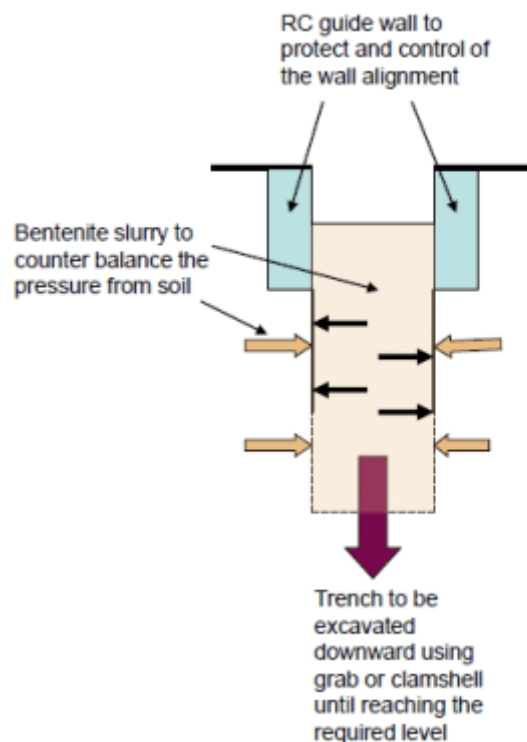
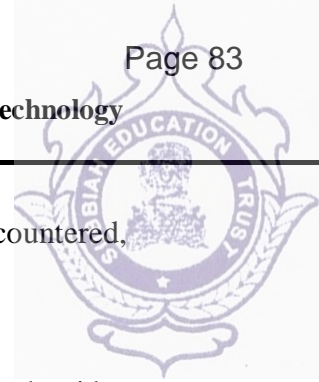

Fig.2. Guide Wall Constructed to Prevent Soil Collapse during Trenching

As the slurry levels of soil vary largely, it is necessary to have a temporary support like guide wall. The dimensions of the guide wall constructed changes with the type of surface soil. In case, the water table level in the area is too high, the guide wall is constructed at a height above the ground level to guide the construction.

2. Excavation of Panel

This stage includes soil-removal and stabilization. A rectangular excavation tool is used to excavate the panel section. A clamshell or grab is used to excavate the trench in normal soil.



Grab suspended by a crane or cable easily moves into the soil. If any obstruction is encountered, it is broken by the means of a gravity hammer and taken out by means of the grab.

The above procedure must be conducted with adequate excavation support, otherwise, the sides of the excavated trench can collapse. To protect the sides, bentonite slurry is used. The slurry helps in producing lateral pressure that is sufficient to retain the vertical soil.

3. Wall Concreting

This stage involves the concreting of the panel excavated. Initially, the reinforcement cage is inserted into the trench. If the depth of the diaphragm wall is more, two or more steel reinforcement cages have to be inserted to cover the depth and these cages are lapped.

Once the reinforcement is placed, the concrete is poured into the trench with the help of tremie pipes. The use of tremie pipes helps to avoid segregation of concrete. The poured concrete replaces the bentonite clay in the trench. The density of bentonite is low compared to concrete hence is replaced during the concreting. The bentonite clay displaced is collected and reused.

Materials for diaphragm walls

Materials used for d-walls are

- cement,
- an aggregate of a certain size,
- sand,
- water,
- chemical admixtures,
- reinforcement via steel bars
- bentonite

Diaphragm Wall Connections

Mainly two types of joint design are employed in diaphragm walls. They are by using:

1. Stop End Pipes
2. Disposable Pipes

1. Stop End Pipes

In this method, two steel pipes are inserted into the trench before concreting, so that after concreting a semi-circular end section panel is obtained. The panel formed with concave ends

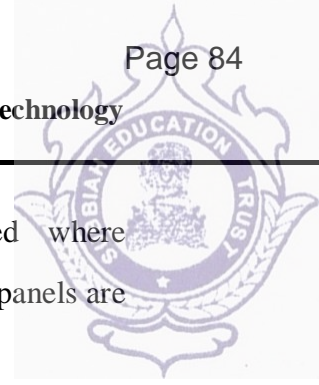

forms the primary panel. Alternatively, an intermediate section is formed where the secondary panel is constructed. Once the primary panel is made, the secondary panels are executed.

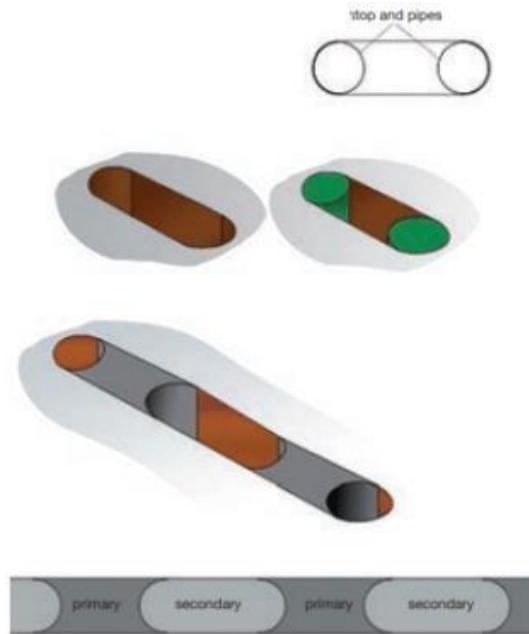

Fig.3. Diaphragm Joints by Stop end Pipes;

2. Disposable PVC Pipes

In this method, two pipes are arranged at the ends of the steel reinforcement cage of the panel. The concreting is performed for the primary panel leaving the pipes with slurry. During the concreting of the secondary panel using a dedicated tool, the separation is broken as shown in figure -4 below. A round indentation is made in the primary panel in connection with secondary. While concreting the secondary panel, the indentation too is filled thus making a joint with the primary panel.



Fig.4. Diaphragm Joints by Disposable PVC Pipes

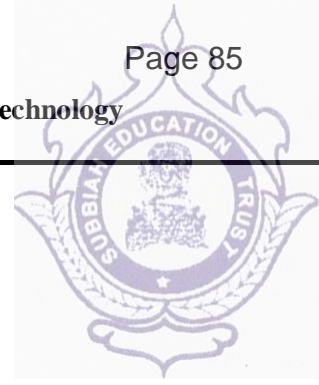

Application of diaphragm walls

Diaphragm walls work well for the following situations:

- In areas of dense infrastructure
- In areas where a very rigid retention system is required
- In areas where vibration and noise are to be minimal
- In areas where dewatering is not possible
- In areas where the geology restricts a conventional retention system.

The most common applications are areas such as tunnels, deep basements, underpasses, underground car parks, and railway stations.

FLOORING

Flooring adds an aesthetic appeal and improves the value of your home. Unlike furniture and fittings that can be changed on a regular basis, flooring is a fairly permanent component of your home decor. Changing the flooring is an extensive, expensive, and tedious undertaking.

Different types of flooring materials are available in the market, each having their own pros and cons. The wide variety of flooring materials available in the market can make it tough for you to choose the most suitable one for your home.

Factors to be considered choosing flooring

- Lifestyle
- Advantages with respect to its usage and function
- Quality
- Ease or difficulty of installation
- The level of finishing needed
- Maintenance and cleaning
- Budget
- Expected foot traffic on the Flooring

Here are a few types of flooring materials which modern homeowners use these days.

(A) Tiles Flooring

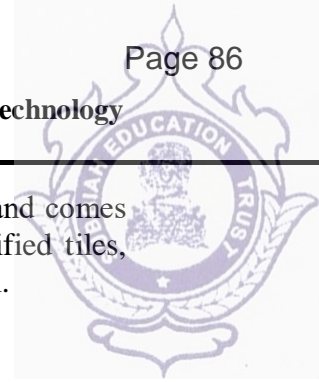

The tile flooring is a popular option among homeowners as it's highly versatile and comes in a variety of colors, textures, and patterns. Flooring Tiles are available as vitrified tiles, ceramic tiles, porcelain tiles, and many more. Let's understand each type in detail.

01. Ceramic Tiles Flooring

Ceramic tiles are made of a mix of clay and water. These tiles are a great modern flooring option, used indoors and outdoors. Ceramic tiles are ideal for installing in moist areas like bathrooms and kitchens as these tiles are not as slippery as compared to vitrified tiles.

02. Vitrified Tiles

A vitrified tile is a type of ceramic tiles with lower porosity. Vitrified tiles are most commonly used in areas with high foot traffic like the living room, kitchen, or bedroom. These tiles are made with a typical glossy finish. However, these days vitrified tiles with a matt finish are also available.

Full Body Vitrified Tiles

Full body vitrified tiles display unique pigment through the entire thickness of the tile body. Therefore, these tiles are scratch-proof. Further, during the tile cutting process, the borders can be created with the same tiles to create a cohesive effect.

Double Charged Vitrified Tiles

Double-charged vitrified tiles are fed through a press that prints the pattern with a double layer of pigment (two kinds of colours are fed into the machine). Therefore, the upper layer becomes 3 to 4 mm thick. This tile is a viable option for the medium to heavy-traffic areas in your home. Price-wise, these tiles are cheaper than full body vitrified tiles.

Soluble Salt Vitrified Tiles

These are vitrified tiles that get printed with the screen-printing technology and then polished to give them a unique look. So, after using liquid colour for screen printing, the tile is subject to high pressure wherein the soluble salt liquid is infused to give them a specific colour and pattern. Hence, the name soluble salt vitrified tiles.

Glazed Vitrified Tiles

Glazed Vitrified Tiles (GVT) offers a glazed surface, which makes it an ideal choice for many types of interior designs and surface textures. Since these tiles boost the aesthetic appeal of the interiors, they are widely preferred by homeowners and interior designers.

3. Porcelain Tiles Flooring

Porcelain tiles are a special type of vitrified tiles. Presently, the use of these tiles has become limited. In the recent past, porcelain tiles were popularly used in the living room as well as in bedroom flooring. These tiles are stain-proof and moderately water-resistant.

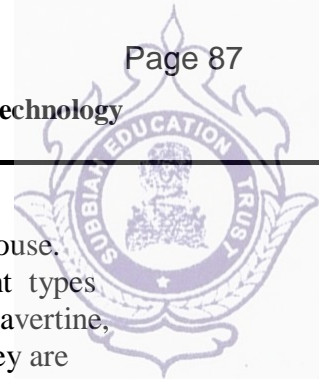

(B) Stone Flooring

Stone flooring is natural, beautiful, and make an excellent focal element for a house. They are durable in comparison to synthetic or manmade stone options. Different types of natural stones are available today, namely granite, marble, limestone, slate, travertine, and sandstone among others. Though each of them has unique characteristics, they are hard by nature. Since they are naturally cool, they are ideal for houses located in warm and tropical climatic conditions.

04. Marble Flooring

Marble is a metamorphic rock. When properly finished, marble adds a grandeur appeal to the home interiors. This makes it a luxurious option for home flooring. Marble is classified in four grades, namely Grade A, Grade B, Grade C, and Grade D. These grades define the quality of marble.

Marble flooring is very common in residential and commercial buildings, temples, hotels, and hospitals. It comes in different colours, such as pink, white, brown, black, and green. According to the 'CPWD Specifications', the most popular marble categories available in India are Makarana Marble, Ambaji Green Marble, Kesarayaji Green Marble, Rajnagar Plain White, and Udaipur Green Marble.

05. Granite Flooring

Granite is an igneous rock that's used as a dimension stone for residential and commercial buildings. Granite flooring is a type of natural stone flooring that's ideal for installing in the kitchen and the surrounding areas. Granite is also used in outdoor areas like driveways, stair treads, and swimming poolside. Though it's a natural stone, granite flooring does not feel as cold as marble. Jhansi Red, Sindoori Red, and Baltic Brown are some of the popular granite varieties available in India.

06. Limestone Flooring

Limestone flooring is known for its naturally-attractive texture. Limestone is a sedimentary rock that often features fossilized patterns, making it a perfect choice for bathrooms, dining rooms, and hallways. Kota blue, Jaisalmer yellow, and natural black are the popular limestone varieties available in India.

Listed below the popular limestone used in flooring mostly in India:

Kotah Stone Flooring

Kotah Stone is one of the most popular limestone varieties used for flooring in India. It is cheaper than marble and often used in the lobby, balcony, and pathways. It is not as attractive as marble and granite flooring.

Cleaning of Kota stone flooring is not difficult if the stones are polished adequately. Nowadays, with mirror polishing, they look pretty attractive. This stone flooring is known for its durability and long service life.

Normally, polished Kota stones are slippery; therefore, they cannot be used in public places like hospitals, corridors, or schools. In such areas, rough Kotah stone is used to avoid accidental slips and falls.

Travertine Flooring

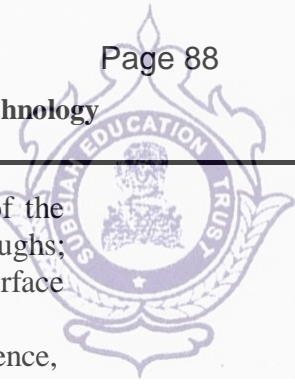

Travertine is another type of limestone flooring. Nowadays, the travertine is one of the softest flooring available in the market. It is characterized by pitted holes and troughs; but these anomalies are often filled before honing or polishing, to get a smooth surface finish. This stone is a popular modern flooring option for kitchens and bathrooms. Travertine flooring can be more susceptible to staining than granite or marbles. Hence, these tiles demand periodic cleaning and maintenance. To get more information on travertine floor, read:

07. Sandstone Flooring

Sandstone flooring is composed of loose grains of quartz sand that render a rough texture to the tile. Its inherent natural beauty makes sandstone flooring a great option for interior floors as well as exterior decoration including flooring, paving, or parking. Some of the popular sandstone in India are Jodhpur Pink, Agra Red, Dholpur Red, Rajula Pink.

PLASTERING

Plastering is the process of covering rough walls and uneven surfaces in the construction of houses and other structures with a plastic material, called plaster, which is a mixture of lime or cement concrete and sand along with the required quantity of water.

What is the purpose of plastering?

Plastering makes the rough surfaces of the walls smooth. Plastering covers rough edges and uneven surfaces, thus increasing durability and strengthening walls. Plastering also gives a good finish to the walls of your house and this will make the home look appealing.

POINTING

Pointing is the art of finishing the mortar joints of the walls or similar structures with either cement mortar or lime mortar in order to protect the joints from atmospheric agencies and also to improve the appearance of the structure.

Pointing is the finishing of mortar joints in brick or stone masonry construction. Pointing is the implementing of joints to a depth of 10 mm to 20 mm and filling it with better quality mortar in desired shape. It is done for cement mortar and lime mortar joints.

.

Importance Of Pointing

Some importance of pointing work is:

- a. It helps to seal the voids or spaces which may carry water and cause decaying of joints mortar.
- b. Regular maintenance is reduced if pointing work is done properly and aesthetically.
- c. It gives strong and reliable bond finishing at joints of bricks /stone masonry.

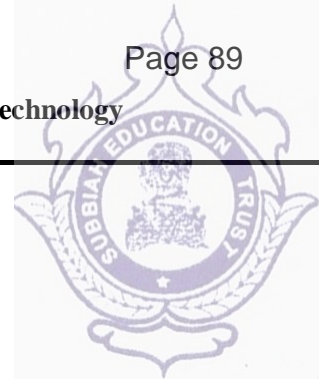

d. It also has scope in various places even in low precipitating areas.

Uses Of Pointing

Some uses of Pointing are:

- a. It can be used to fill the gaps at joints of brickwork walls using cement mortar.
- b. Repointing can be done to maintain and repair the cracks on the structures.
- c. Stones can be used for pointing in the stone masonry to make the structure strong and stable.
- d. Sometimes, people also do point to give an aesthetic look to their building.

ROOF

- A roof is covering of the top of a building, serving to protect against rain, snow, sunlight, wind, and extremes of temperature
- Roofs do much more than just serving the basic purpose of protecting a home and its occupants from sun, wind, rain, snow and other outside elements
- For instance, the shape of a roof plays a huge role in defining and characterizing the complete look and elegance of a house
- In addition to this, a roof plays a prominent role in making a home more resilient, weatherproof and energy efficient, also it provides some additional living space.

Roof Designs, Shapes & Styles

Depending on a home's architecture, a roof can potentially make up 40% of the exterior, often playing a big role in its overall look and curb appeal. So, when the time comes to install a new roof, you'll want to pick roofing materials and shingle colors that work well with the shape and slope of your roof, as well as complement your home's exterior design.

Roof Slope

The slope of your roof has both a practical and aesthetic function. Water from rain or snow, for example, tends to shed, or run off, quicker on a steep slope roof. The roof's slope is expressed in a ratio based on the roof's proportions.

SCAFFOLDING

The scaffolding is a temporary structure (usually of timber or steel) having platform raised for the workers as the building increases in height. An ordinary scaffolding consists of standards, ledgers, putlogs, transoms, braces, bridle, guard rail, tee board. Depending on the work conditions, different types of scaffolding are used.

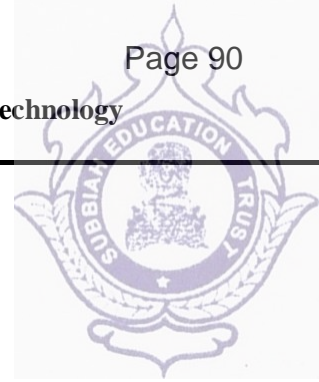

Most common types of scaffolding used in the construction of any structure.

Types of Scaffolding

1. Single Brick-Layers Scaffolding.

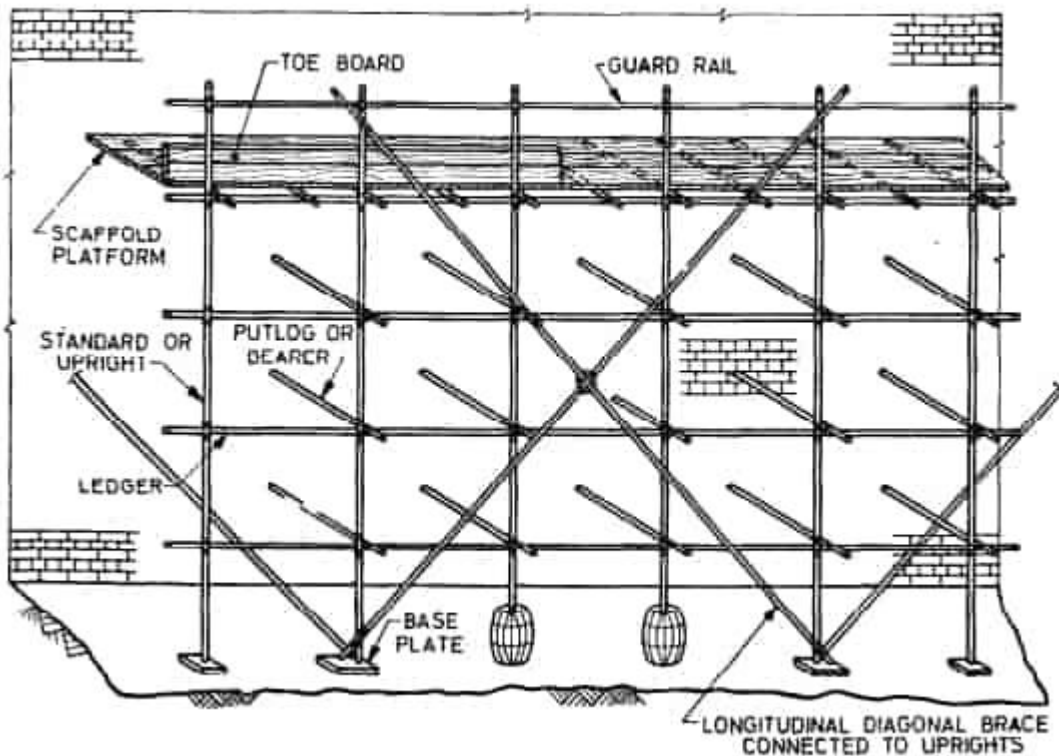

This is the most common type of scaffolding and is widely used in the construction of brick work. This type of scaffolding is, sometimes known as *putlog scaffolding*. It is mostly used for brick masonry construction. This type of scaffolding consists of various scaffolding parts such as:

Scaffold: A temporary structure consisting of standards, putlogs, ledgers which are generally made up of bamboo, timber or metal to provide a working platforms for workmen and materials in the course of construction, maintenance, repairs and demolition, and also to support or allow hoisting and lowering of workmen, their tools and materials.

Standard or Upright: A vertical member used in the construction of scaffold for transmitting the load to the foundation.

Ledger: A horizontal member which ties the standard at right angles and which may support putlogs and transoms.

Putlog / Bearer : A scaffolding member spanning from ledger to ledger or from ledger/ standard to a building and upon which the platform rests.

Transom: A member spanning across ledgers/ standards to tie a scaffold transversely and which may also support a working platform.

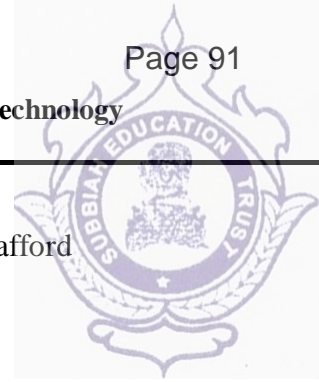

Brace: A member fixed diagonally across two or more members in a scaffolding to afford stability.

Bracing: Bracing is a system of braces or ties that prevent distortion of a scaffold.

Guard Rail: A horizontal rail secured to uprights and erected along the exposed edges of scaffolds to prevent workmen from falling.

Toe-Board: A barrier placed along the edge of the scaffold platform and secured there to guard against the falling of material and equipment.

Base Plate: Base plate is used so that the standard/ poles do not get inserted into the ground due to the heavy load on the top of the scaffold boards due to the masons. These base plates are generally made up of hard metal.

2. Double or Mason's Scaffolding.

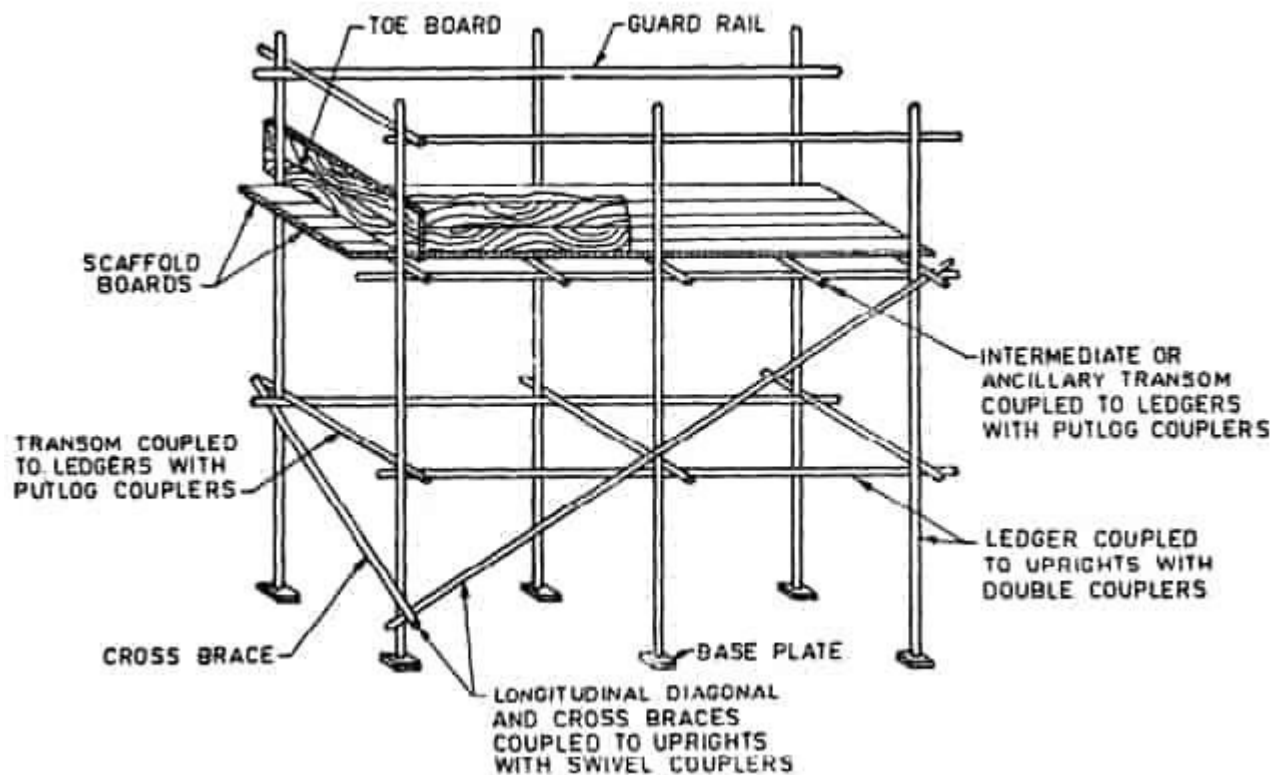

This scaffolding is stronger than single scaffolding type and is used in the construction of stone work. This type of scaffolding is sometimes known as independent scaffolding. As seen in the above picture there are 2 rows of standards used in the construction of this scaffolding. One row is placed just next to wall and another row is placed 1.2 to 1.5 meter from the wall.

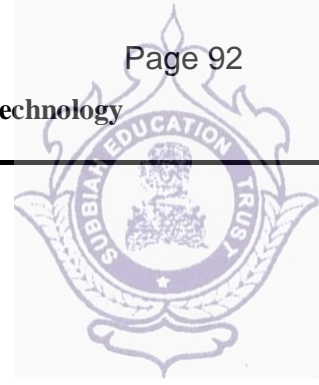

3. Cantilever or Needle Scaffolding.



This type of scaffolding is used under the following circumstances:

- When the ground is weak to support the standards.
- When the construction for the upper parts of a multi- storied building is to be carried out.
- When the ordinary scaffolding will obstruct the traffic on road such as for a building on the side of a busy street.
-

4. Suspended Scaffolding.



This is a light weight scaffolding used for repair works such as painting, pointing, white washing, distempering etc of the exterior surface of the building. The working platform is suspended from the roof by means of wire ropes, chains etc. The platform can be raised or lowered at any desired level.

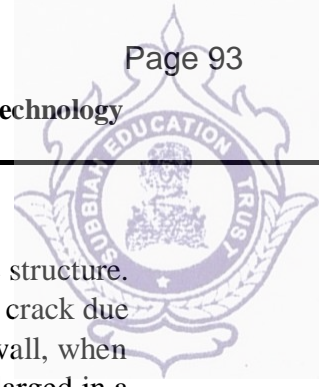

SHORING

Shoring is the construction of a temporary structure to support temporarily an unsafe structure. These support walls laterally. Shoring can be used when walls bulge out, when walls crack due to unequal settlement of foundation and repairs are to be carried out to the cracked wall, when an adjacent structure need pulling down, when openings are to be newly made or enlarged in a wall.

Types of shoring

1. Raking shoring
2. Flying shoring
3. Dead shoring

1. Raking Shoring

In this method, inclined members known as rakers are used to give lateral supports to walls (figure 1 to 3). A raking shore consists of the following components:

1. Rakers or inclined member
2. Wall plate
3. Needles
4. Cleats
5. Bracing
6. Sole plate

The following points are to be kept in view for the use of the raking shores:

1. Rakers are to be inclined in the ground at 45° . However, the angle may be between 45° and 75° .
2. For tall buildings, the length of the raker can be reduced by introducing rider raker.
3. Rakers should be properly braced at intervals.
4. The size of the rakers is to be decided on the basis of anticipated thrust from the wall.
5. The centre line of a raker and the wall should meet at floor level.
6. Shoring may be spaced at 3 to 4.5m spacing to cover longer length of the bar.
7. The sole plate should be properly embedded into the ground on an inclination and should be of proper section and size.
8. Wedges should not be used on sole plates since they are likely to give way under vibrations that are likely to occur.

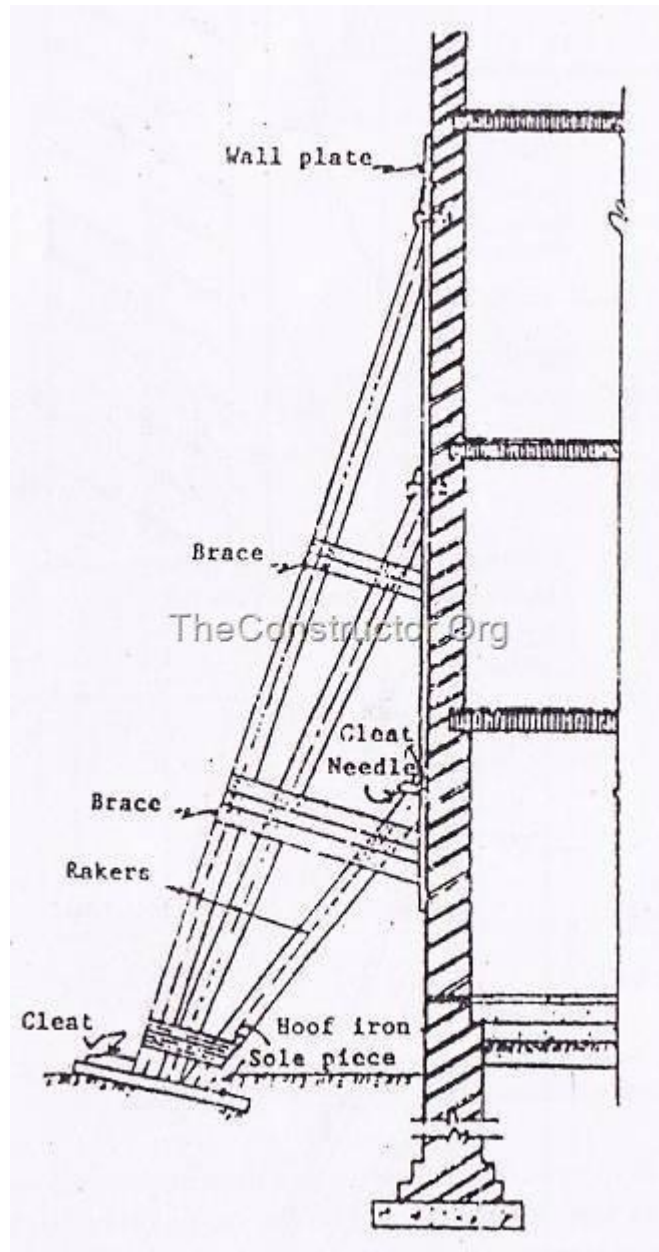
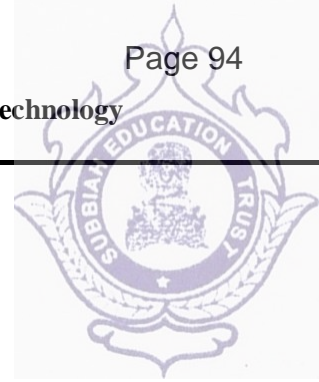

Fig.: Raking Shores Wall Support

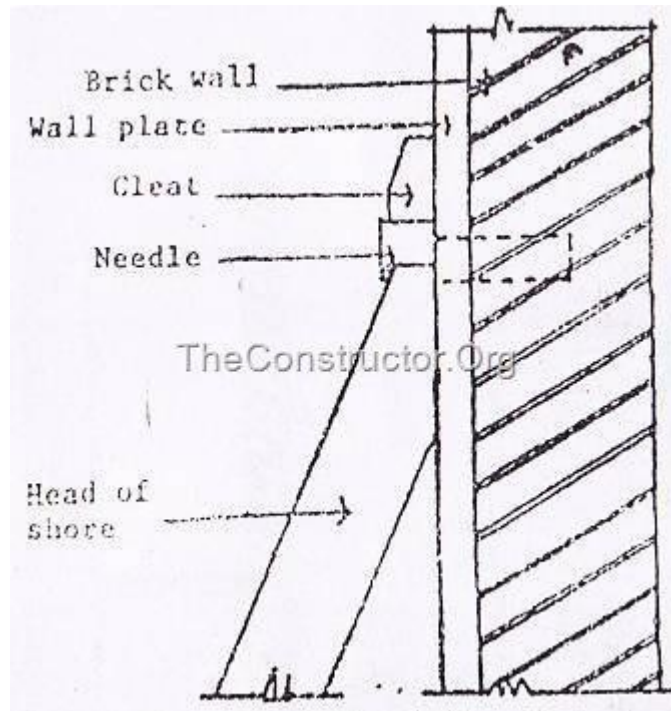
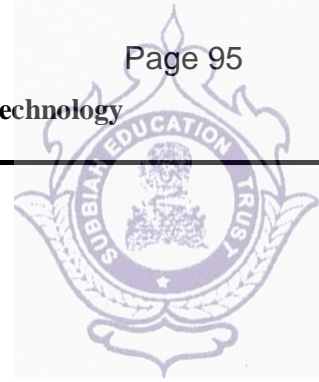

Fig.: Detail of Head of the Raker Shores

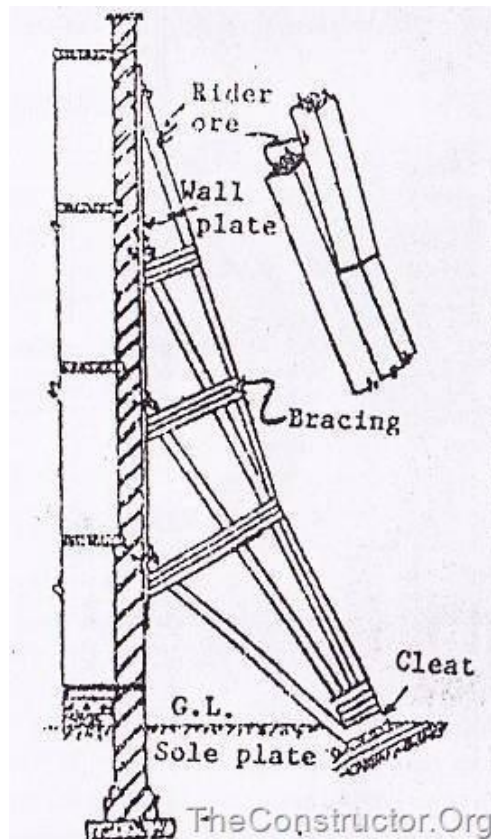
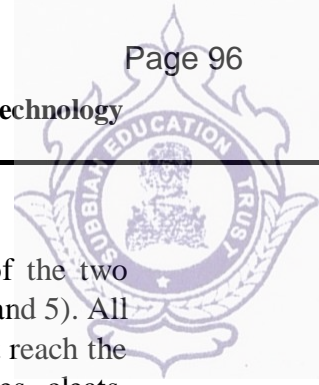

Fig.: Raking shore for Multistoried Building where inclination of the rakers has to be limited due to short land width available



2. Flying Shoring

Flying shores is a system of providing temporary supports to the party walls of the two buildings where the intermediate building is to be pulled down and rebuilt (figure 4 and 5). All types of arrangements of supporting the unsafe structure in which the shores do not reach the ground come under this category. The flying shore consists of wall plates, needles, cleats, horizontal struts (commonly known as horizontal shores) and inclined struts arranged in different forms which varies with the situation. In this system also the wall plates are placed against the wall and secured to it. A horizontal strut is placed between the wall plates and is supported by a system of needle and cleats. The inclined struts are supported by the needle at their top and by straining pieces at their feet. The straining piece is also known as straining sill and is spiked to the horizontal shore. The width of straining piece is the same as that of the strut. When the distance between the walls (to be strutted apart) is considerable, a horizontal shore cannot be safe and a trussed framework of members is necessary to perform the function of flying shore.

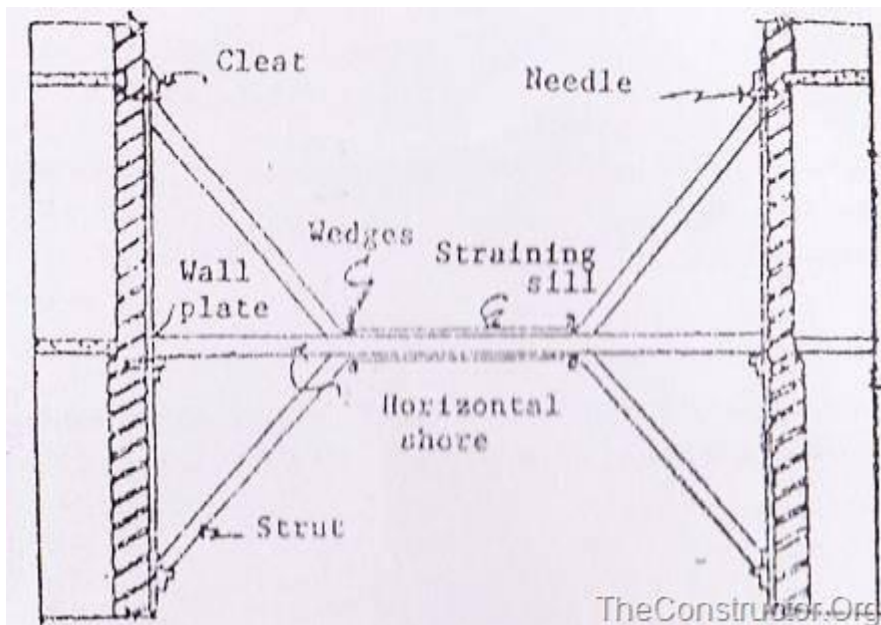

Fig.: Flying Shore

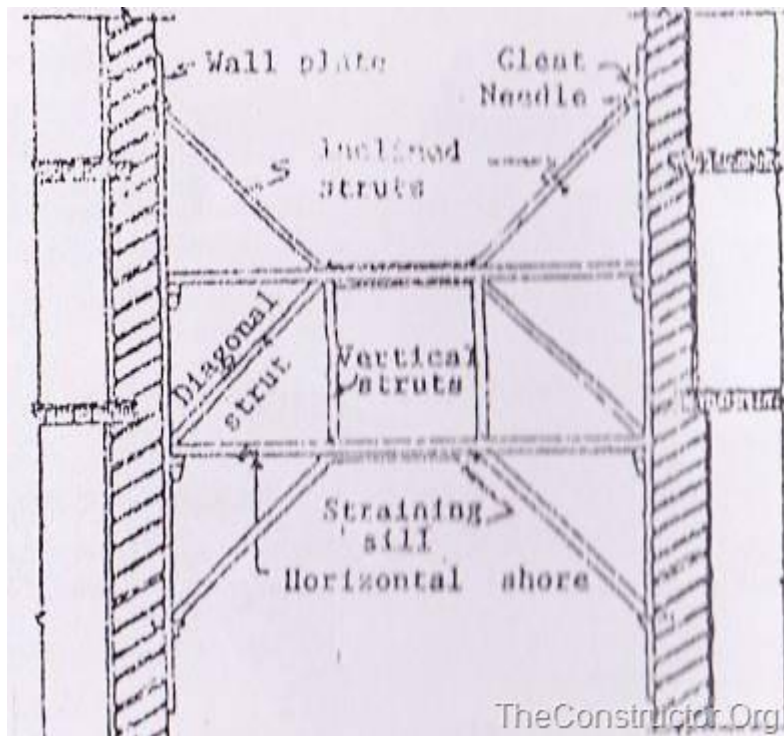
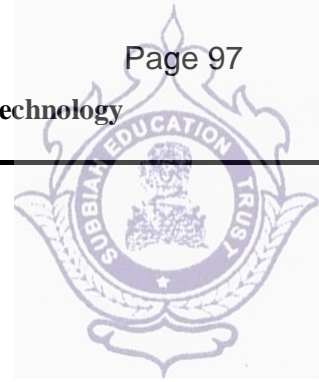

Fig.: Flying shore when the distance between two walls is considerable

3. Dead Shoring

Dead shore is the system of shoring which is used to render vertical support to walls and roofs, floors, etc when the lower part of a wall has been removed for the purpose of providing an opening in the wall or to rebuild a defective load bearing wall in a structure. The dead shore consists of an arrangement of beams and posts which are required to support the weight of the structure above and transfer same to the ground on firm foundation below.

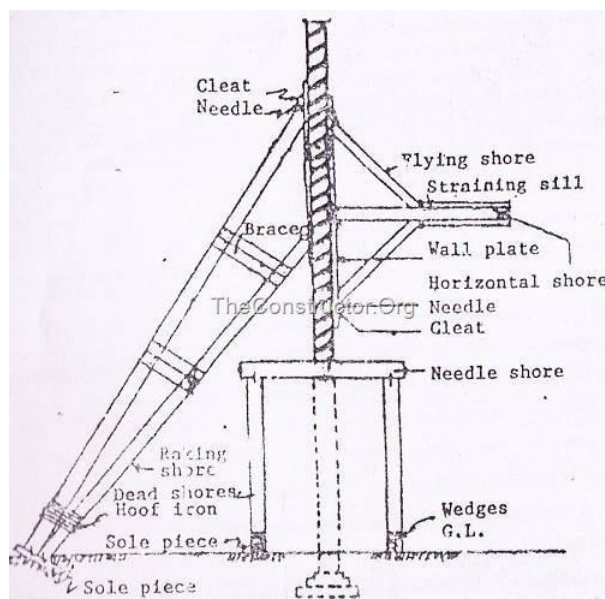

Fig.: Dead Shore

When opening in the wall are to be made, holes are cut in the wall at such a height as to allow sufficient space for insertion of the beam or girder that will be provided permanently to carry

the weight of the structure above. Distance at which the holes are cut depends upon the type of masonry and it varies from 1.2m to 1.8m center. Beams called needles are placed in the holes and are supported by vertical props called dead shores at their ends on either side of the wall. The needles may be of timber or steel and are of sufficient section to carry the load above.

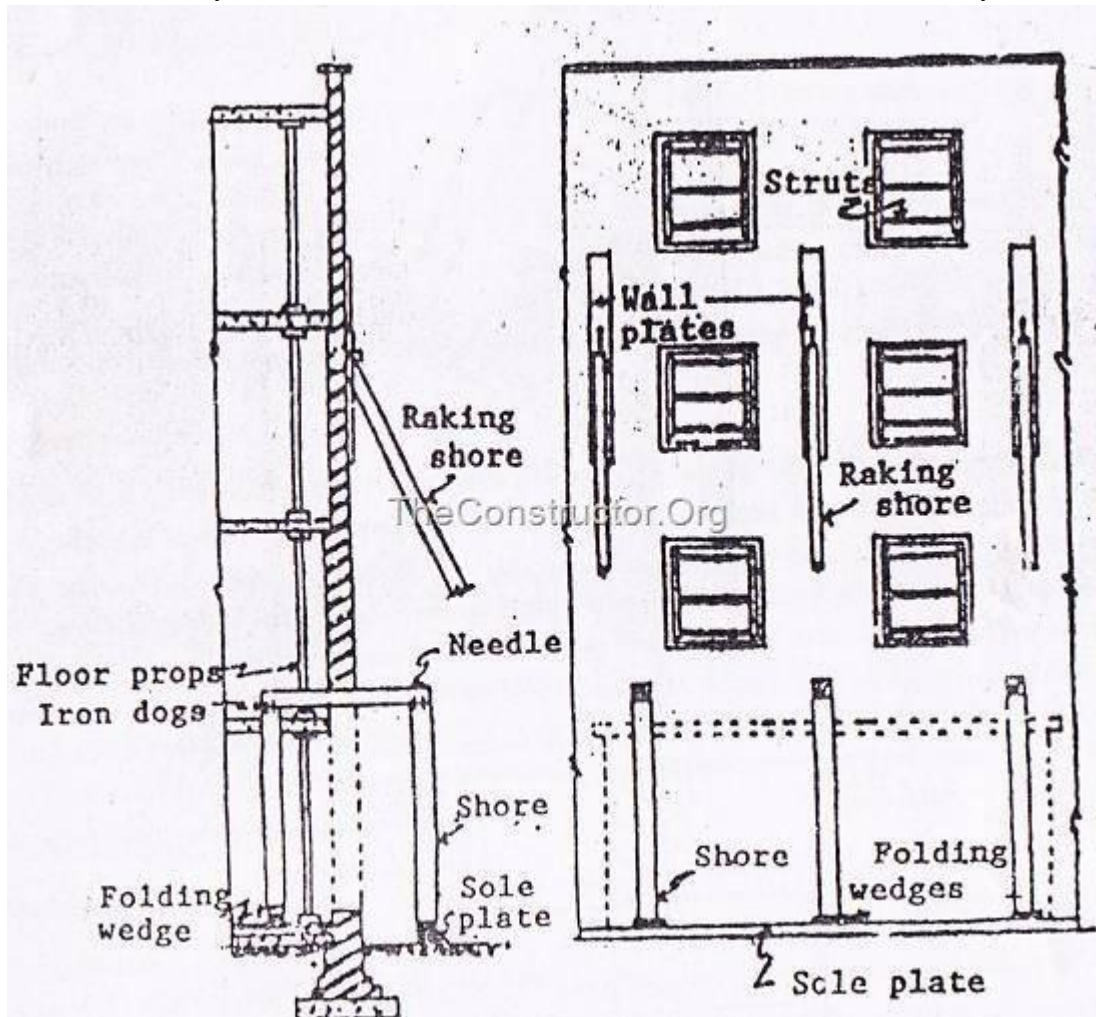
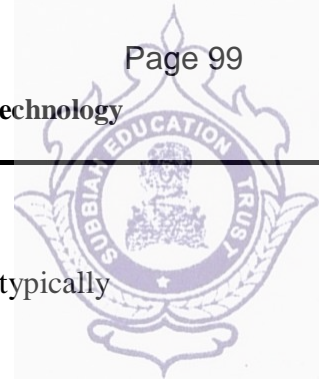

Fig.: Section of the elevation showing arrangement of dead shores for making an opening in an existing wall

The dead shores stand away from wall on either side so as to allow for working space when the needle and the props are in position. The props are tightened up by folding wedges provided at their bases while the junction between the prop and the needle is secured with the help of dogs. Before the dismantling work is started, all the doors, windows or other openings are well strutted. In order to relieve the wall of load of floors and roof above, they are independently supported. Vibrations and shocks are bound to occur when wall cutting is done as such a measure of safety raking shores are sometimes erected before commencement of wall cutting operation.



UNDERPINNING

Underpinning is strengthening and reinforcing an existing foundation of a structure, typically by extending the depth and breadth of the foundation.

Purpose of Underpinning

Underpinning is done for the following purposes:

- For the purpose of leading an old shallow foundation to the deeper depth when the adjoining building is constructed with a deep foundation.
- Underpinning is done for building a basement in the existing building.
- Underpinning is done to deepen the existing foundation (resting on poor strata) and make it rest on deeper soil strata of higher bearing capacity.
- To strengthen a settled foundation that may be caused by cracks in the wall.

Necessary of underpinning

1. Uneven settlement is caused by the unsymmetrical loading of the building, unequal bearing capacity of all the soil beneath the foundation, By the action of tree roots, or primary or secondary settlements consolidation cohesive soil.
2. Increase in loading: the loading process of building man changed due to the addition of more story or change in the imposed loading due to change in service loading.
3. Lowering of adjacent ground: Nearby Foundation you stop to work available then it is necessary to lower the foundation of the building.

Methods of Underpinning

Underpinning can be carried but by the following methods:

1. Pit method
2. Pile methods
3. Underpinning to walls
4. Jack pile underpinning
5. Needle and pile underpinning
6. 'Pynford' Stool method of underpinning
7. Root pile or angle Piling Underpinning columns

PIT METHOD

In this method, the entire length of the foundation to be underpinned is divided into sections of 1.2 to 1.5 m lengths. One section is taken up at a time. first of all, a hole is made in the wall for all divided sections above the plinth level, and needle is inserted in the hole. The needle may be made of a material of stout, timber or steel section.

Bearing plates are placed above the needle to support the masonry above it. The supporting arrangement of the needle is made by crib supports (wooden blocks) on both sides of the wall and screw jacks.

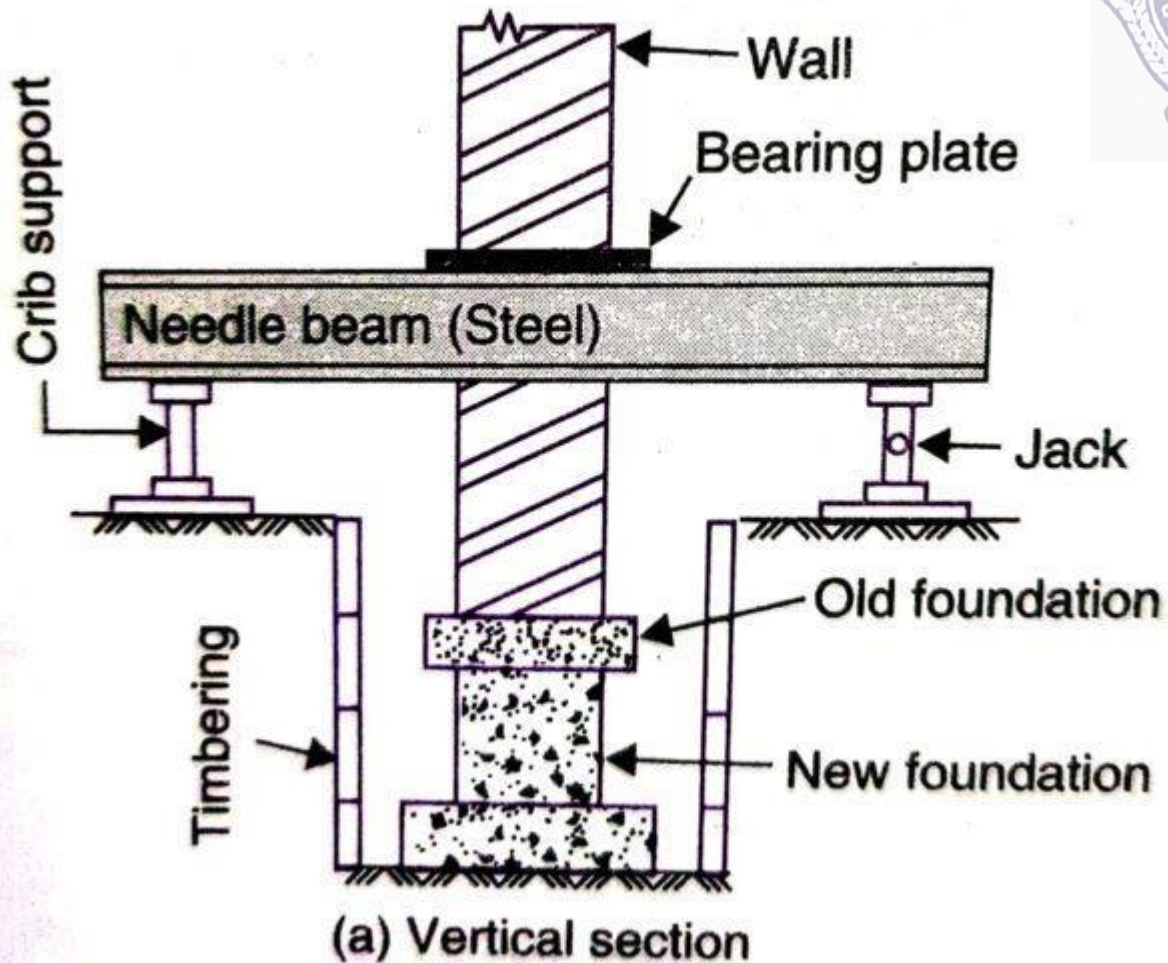
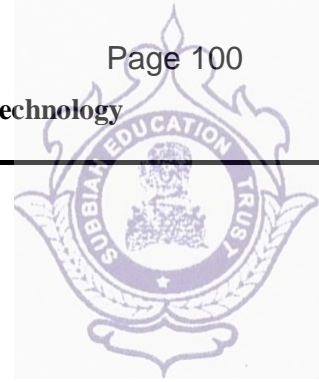

Fig. 2. Pit Method of Underpinning

After that, a foundation pit is excavated up to the required level of new foundation. Then the new foundation is laid in the pit. When the work of one section is over, work on next to next section is taken up, i.e., alternate sections are underpinned in the first round, and then the remaining sections are taken up.

Some important precautions should be taken during the work, such as raking shores are provided in weak wall, floors are also supported.

In this process cantilever needle beams may be used when a strong interior column is there, or if there is a required foundation increasing in only one side, as shown in Fig. 3.

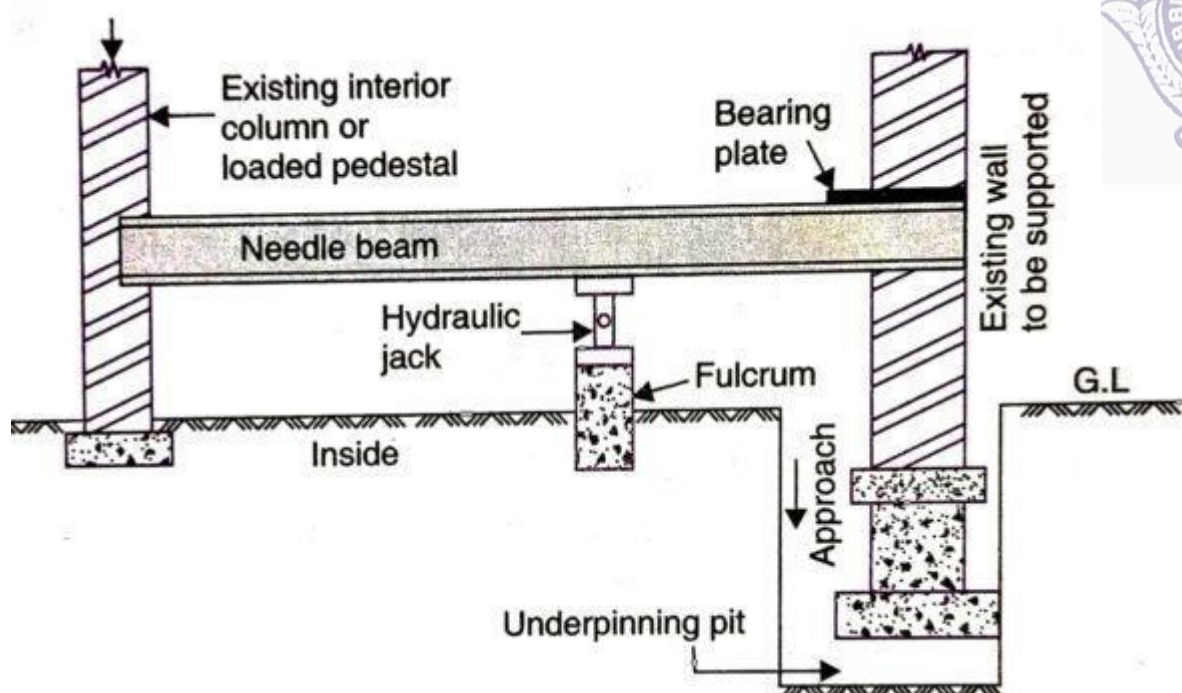

Fig. 3. Pit Method of Underpinning with Cantilever needle

The following points are to be considered in the pit method:

1. Alternate sections are taken up in the first round. The remaining intermediate sections are then taken up. Only one section should be taken at a time.
- It is better to start the work from the middle in the case of longwall extended in both directions.
 - If the new foundation is deeper, proper timbering of the foundation trench may be done.
 - When the foundation has gained full strength then only all the arrangements like needle beams etc. should be removed slowly.
 - The needle holes etc. should be closed in masonry using cement mortar.

PILE METHOD

In the Pile method of underpinning, as the name suggests Piles are installed by proper driving technique along both sides of the wall to be strengthened. The piling technique normally used are borehole pile on under-reamed piles are used.

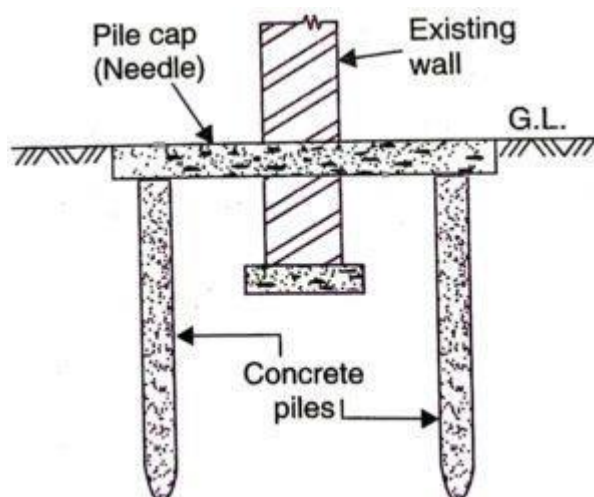

Fig. 3. Pile Method of Underpinning

After that, concrete or steel needles are penetrated through the wall and are connected to the Pile. These needles function is as beams and is act as pile caps also.

Pile method is suitable for clayey soils, waterlogged areas, and also in weak bearing strata.

Besides from above, followings are the Underpinning Types and Techniques used for different structures:

Underpinning to walls:

For underpinning work in walls, the wall should be divided into legs for bays and is bay is treated individually that prevents fracture, damage, or settlement of the walls.

VENTILATION

Mechanical ventilation

Mechanical fans drive mechanical ventilation. Fans can either be installed directly in windows or walls, or installed in air ducts for supplying air into, or exhausting air from, a room.

The type of mechanical ventilation used depends on climate. For example, in warm and humid climates, infiltration may need to be minimized or prevented to reduce interstitial condensation (which occurs when warm, moist air from inside a building penetrates a wall, roof or floor and meets a cold surface). In these cases, a positive pressure mechanical ventilation system is often used. Conversely, in cold climates, exfiltration needs to be prevented to reduce interstitial condensation, and negative pressure ventilation is used. For a room with locally generated pollutants, such as a bathroom, toilet or kitchen, the negative pressure system is often used.

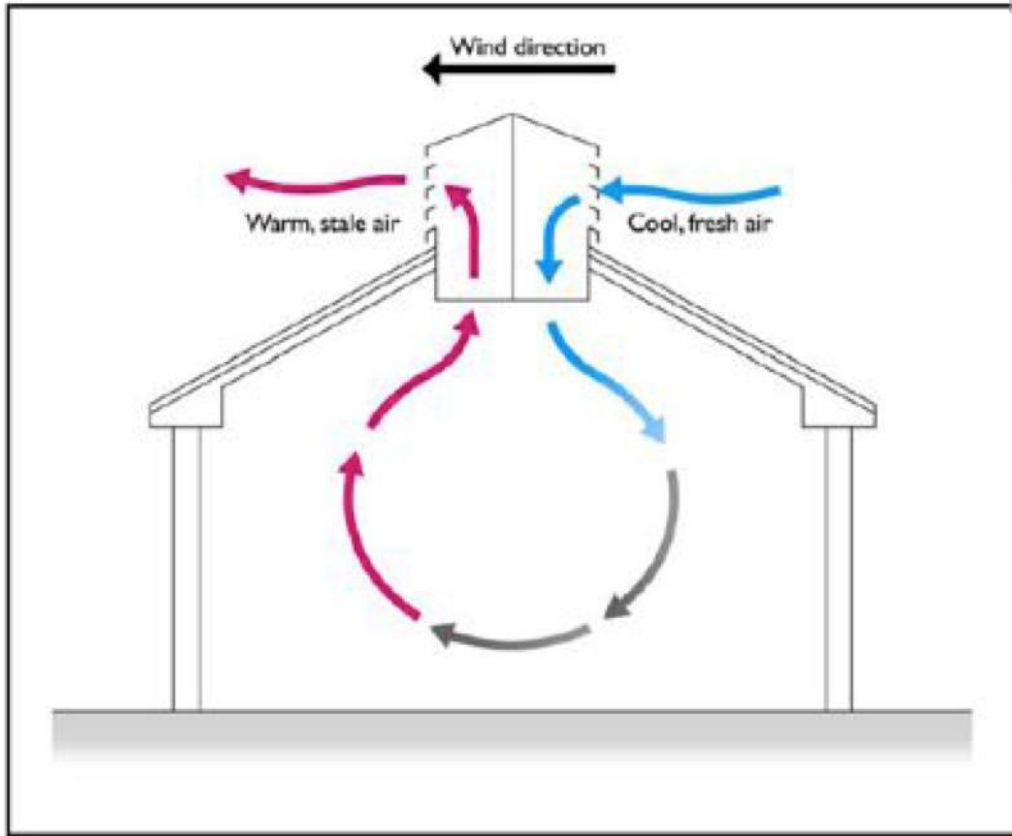
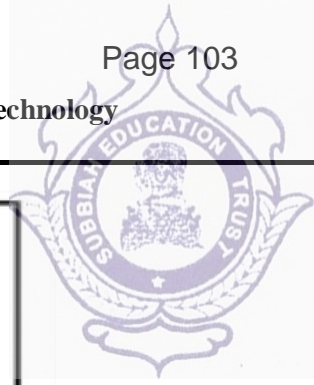

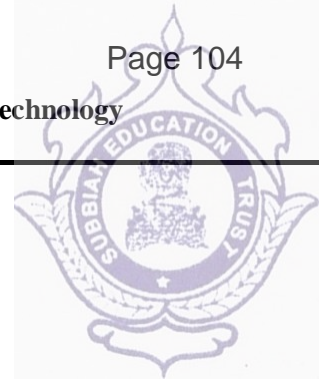

In a positive pressure system, the room is in positive pressure and the room air is leaked out through envelope leakages or other openings. In a negative pressure system, the room is in negative pressure, and the room air is compensated by “sucking” air from outside. A balanced mechanical ventilation system refers to the system where air supplies and exhausts have been tested and adjusted to meet design specifications. The room pressure may be maintained at either slightly positive or negative pressure, which is achieved by using slightly unequal supply or exhaust ventilation rates. For example, a slight negative room pressure is achieved by exhausting 10% more air than the supply in a cold climate to minimize the possibility of interstitial condensation. In an airborne precaution room for infection control, a minimum negative pressure of 2.5 Pa is often maintained relative to the corridor.

What is hybrid or mixed-mode ventilation?

Hybrid (mixed-mode) ventilation relies on natural driving forces to provide the desired (design) flow rate. It uses mechanical ventilation when the natural ventilation flow rate is too low.

Hybrid ventilation takes the advantages of both mechanical and natural ventilation systems, resulting in decreased energy and capital cost when compared to mechanical systems. When compared to natural systems, it is more robust in meeting heat/cooling requirements in a larger array of conditions. This accounts for the growing interest in trying to implement hybrid ventilation systems into buildings, especially school buildings.

When natural ventilation alone is not suitable, exhaust fans (with adequate pre-testing and planning) can be installed to increase ventilation rates in rooms housing patients with airborne infection. However, this simple type of hybrid (mixed-mode) ventilation needs to be used with care. The fans should be installed where room air can be exhausted directly to the outdoor environment through either a wall or the roof. The size and number of exhaust fans depends on the targeted ventilation rate, and must be measured and tested before use.

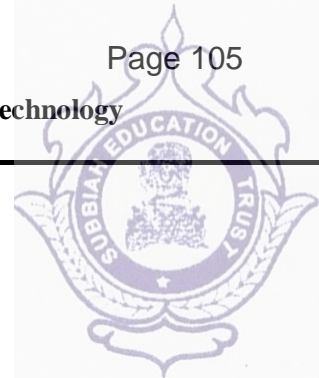

UNIT IV

CONCRETING EQUIPMENT'S

1. Concrete Batching Plant

Also known as concrete plant, this equipment mixes various materials to form concrete. These

materials include sand, aggregate, slag, cement, fly ash, and water among others.

Concrete batching plants come in various types:

1. Dry mix concrete plant
2. Wet mix concrete plant
3. Mobile concrete plant
4. Stationery concrete plant

Temporary site projects and projects that don't require much concrete typically use mobile plants. But projects like ports, bridges, tunnels, dams, and large buildings use stationary ones.



Fig: Dry Mix Concrete Plant

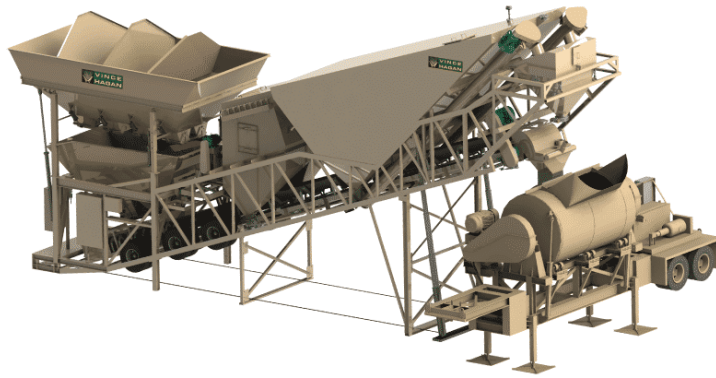
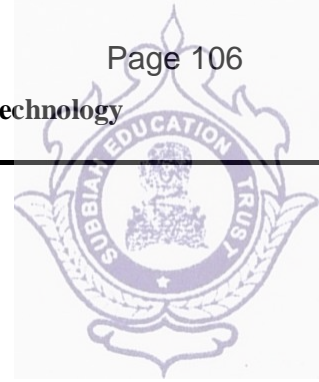

Fig: Wet Concrete Plant



Fig: Mobile Concrete Plant



Fig: Stationary Concrete Plant

The stationary concrete plant is designed to produce high-quality concrete. It has the advantages of large output, high efficiency, high stability and high specification. Stationary concrete batching plants are reliable and flexible, easy to maintain and have a low failure rate.

2. Concrete Pump

A concrete pump is used to transport liquid concrete from the production to the casting area. It works by having one piston draw the concrete from the source and another pushes it into the discharge pipe. There are two types of concrete pump: line and boom. Line concrete pumps are typically used in small construction projects. It uses a line pump attached to the back of a truck, hence the name. While big construction projects use boom concrete pumps as it can pump in different heights and lengths. This makes it ideal for constructing multi-level buildings and bridges.



3. Concrete Mixer



As the name suggests, this equipment mixes cement, aggregates and water to create concrete. It may have the same function as a batching plant but a concrete mixer is usually a single machine. Batching plants, on the other hand, belongs to a whole production line.

Depending on the type, a concrete mixer can produce concrete by batch or continuously. Batch concrete mixers are ideal for small projects where concrete is not on constant demand. While continuous mixers are typically used in big projects like roads, bridges, dams, etc

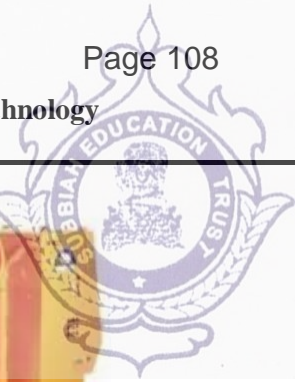

Fig: Concrete Mixers

4. Concrete Vibrator

It's unavoidable for small bubbles to form when concrete is poured. But when left to dry, these bubbles create holes within the concrete and affect its integrity. This is why concrete vibrators are important. By shaking the newly poured concrete, a vibrator forces the air bubbles out. This creates a more compact and stable slab.

Most construction projects use internal vibrators as they are usually cheaper and offer more flexibility. But for vertical constructions like walls, an external vibrator is more suitable.

Different Types of Concrete Vibrators



Fig: Concrete Vibrators

5. Concrete Paver

Also known as a paver or a paving machine, a concrete paver is used to lay asphalt concrete on roads, parking lots, bridges, and other such places. It makes paving much easier and faster

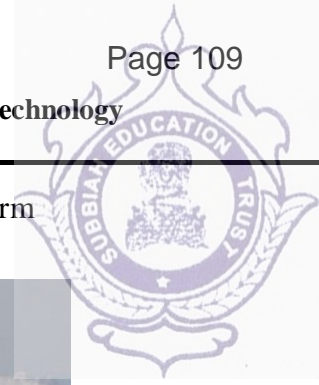

as concrete can be poured continuously from a moving vehicle. It also ensures uniform thickness as the pouring and levelling is done simultaneously.



Fig: Concrete Paver

6. Concrete Crusher

Unlike most types of concreting equipment on this list, a concrete crusher isn't typically used for construction work but for demolition. When buildings are demolished, it usually leaves behind lots of waste concrete. Since they contain high-quality aggregates, throwing them away is a waste of resources. Besides, they take up lots of space and may cause pollution. To avoid this, some construction companies use concrete crushers to recycle waste concrete.

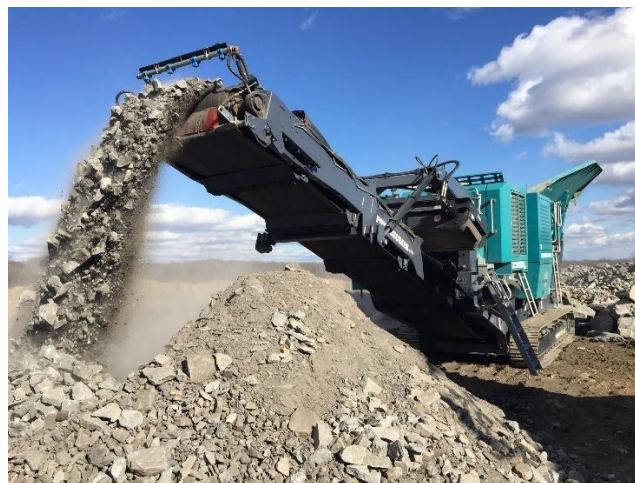

Fig: Concrete Crusher

7. Concrete Conveyor

As the name suggests, a concrete conveyor is a type of conveyor belt that carries concrete horizontally or vertically (in limited distances). This type of conveyor is usually cheaper and may reduce the need for cranes and other such equipment. Concrete conveyors are ideal for

large projects like dams and power plants because of their placing capacity. They also allow companies to save on labor cost as it only requires few people to operate.

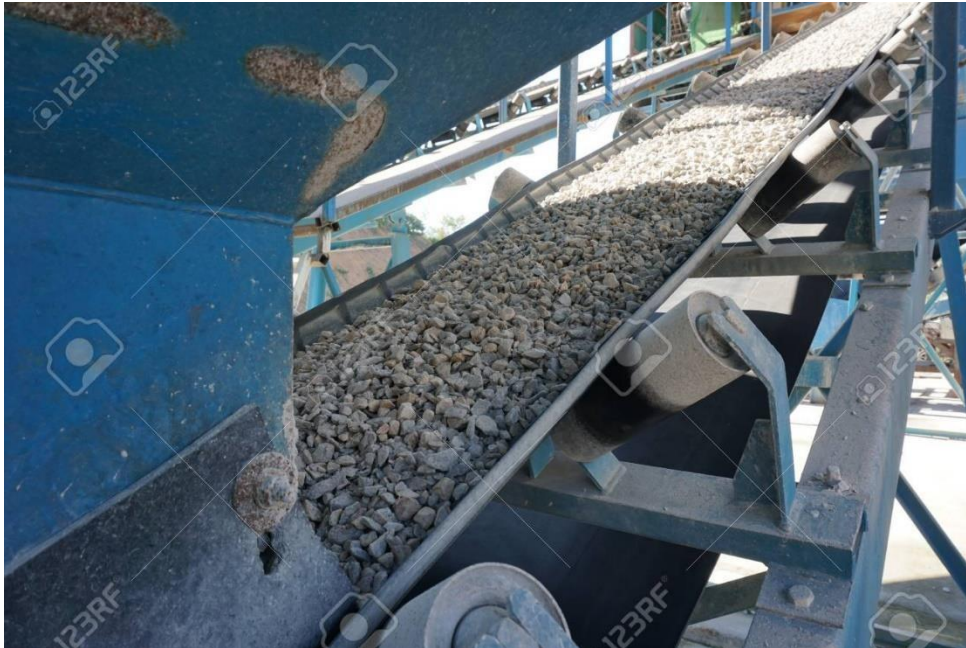

Fig: Concrete Conveyor

SELECTION OF EQUIPMENT FOR EARTHWORK EXCAVATION

Every earthmoving task at a construction site is different. It is, therefore, hard to choose a single earthmoving system for all the tasks. Each earthmoving operation has its objectives and complexity, based on which the best earthmoving system is chosen.

Some of the essential points to be kept in mind to choose the right earthmoving equipment.

1. Identify the Job of Equipment

Almost all earthmoving job includes clearing, excavating, and grading activities. The first important factor to consider while selecting an earthmoving equipment is defining the equipment's role. Some machines perform excavation alone, while some perform site preparation jobs.

2. Study the Site Soil Type

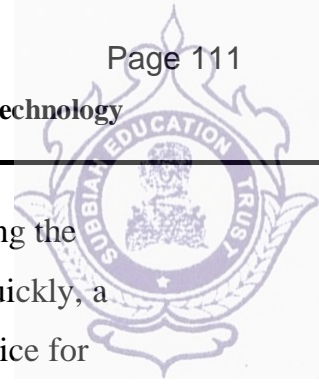

The type of soil is one of the most important criteria to consider when choosing the earthmoving equipment. For example, for smooth soil and soils that spread quickly, a scraper is recommended by engineers. Wheel tractor scrapers are the best choice for areas having sandy, loamy soil.



Scraper Machine used in Construction

For a construction site with hard and rocky soils or wet soils or wet clay material, the decision would be articulated truck. A scraper cannot work in such areas. So, to choose an earthmoving system, one must know the material type that is intended to be moved.



Articulated Trucks Used in Construction

3. Study the Versatility and Flexibility of the equipment

The soil condition varies with the environmental conditions. So, the equipment used to work with the soil must be flexible and versatile enough to adapt to different soil conditions. This is a parameter considered while choosing earthmoving equipment.

Articulated hauler is one such earthmoving equipment that possesses excellent flexibility and versatility property. This equipment works best in limited traction. An articulated hauler is the right choice if the site is subjected to big weather changes.

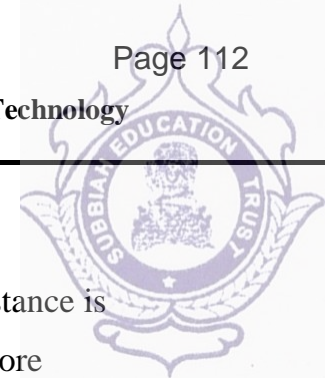

4. Study the Hauling Distance

For smaller hauling distances, small equipment is right. When the hauling distance is higher, and the quantity of earth to be moved is high, it requires heavy and more robust equipment. This is because small equipment cannot sustain the load or pressure for a longer hauling distance. When a small equipment is made to work for larger hauling distance, it results in the machine's breakdown.

5. Determine the Cutting Work

The depth and length of earth cutting also influence the type of earthmoving equipment. A scraper finds it difficult to load the earth if the length of the cut is less than 100 ft. But this case is easily moved by articulated haulers.

In construction areas, where there is enough space for outlining, a scraper works best. For digging a borrow pit, an articulated truck is the right choice.

Understanding Earthmoving Equipment

Every earthmoving operation is a combination of digging, scooping, and pushing the material. The earthmoving equipment is used to perform any of these operations. A contractor or engineer chooses the earthmoving equipment based on the utility and the tasks that need to be completed. The selection of the right earthmoving equipment improves the production and profit.

The three common types of earthmoving equipment used are excavators, loaders, and bulldozers. The features of these equipment and the task performed by each is tabulated in the column below. The understanding of different types of equipment plays a vital role in choosing the right earthmoving equipment.

Features	Excavators	Loaders	Bulldozers
Task	Dredging, demolition, pile driving, material handling, mining	Used to move sand, gravel, snow. Used for small projects	The self-weight of the machine traverses the soil and level it.

Machine Components	Booms and Buckets that can drill and break hard strata	Scooping is performed using a bucket	A giant blade pushes the large quantities. A ripper is attached to tear rock and soil. Without blade and ripper, a bulldozer can fine grade the soil.
Objective	Digging the earth or site material	Scooping the earth or site material	Pushing and smoothening the earth or site material

DEWATERING AND PUMPING EQUIPMENT

* Dewatering equipment are used to perform dewatering on construction sites, which is defined as the process of separating water from another material like saturated soil or sludge.

* The separation of water is performed by using a force generated by vacuum or centrifugal motion. Dewatering equipment saves money by reducing solids handling and disposal expenses. It is

an alternative and economical option compared with heat drying systems for water removal.

* The selection of dewatering equipment depends on the corrosion potential of the material removed and the contaminants present in the liquid. As the reactivity of the liquid increases, the equipment is constructed with more durable materials.



Types of Dewatering Equipment

The common types of dewatering equipment are:

1. Centrifuges
2. Drying beds
3. Vacuum filters
4. Filter presses

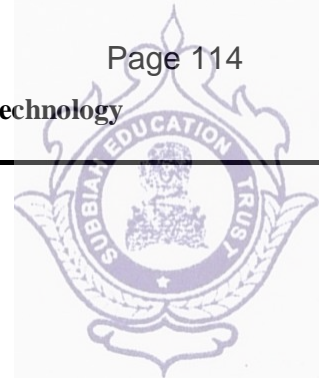

5. Sludge lagoons
6. Gravity and low-pressure devices

1. Centrifuges

Centrifuges remove solids from liquids through the process of sedimentation and centrifugal force. The solids or sludge are fed through the stationary feed tube. The sludge moves with an acceleration through the ports in the conveyor shaft, which is then distributed to the periphery of the bowl.

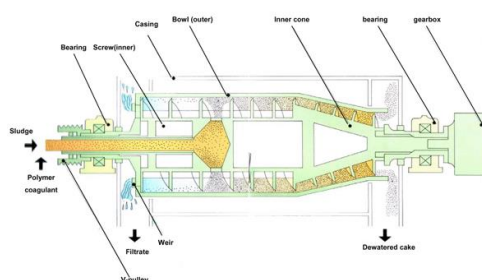

Figure-: Diagram of a typical dewatering centrifuge

The bowl spins at high speed which simultaneously separates water from the solids. The separated solids are compacted against the bowl wall, as shown in the figure. The solids are then conveyed to the centrifuges drying stage and the liquid separated is discharged continuously over the weir arrangements around the sides of the bowl.

2. Vacuum Filters

The main aim of the technique is to extract extra water from concrete surface using vacuum dewatering. As a result of dewatering, there is a marked reduction in effective water-cement ratio and the performance of concrete improves drastically. The improvement is more on the surface where it is required the most. Mainly, four components are required in vacuum dewatering of concrete,

which are given below:

1. Vacuum pump
2. Water separator
3. Filtering pad
4. Screed board vibrator

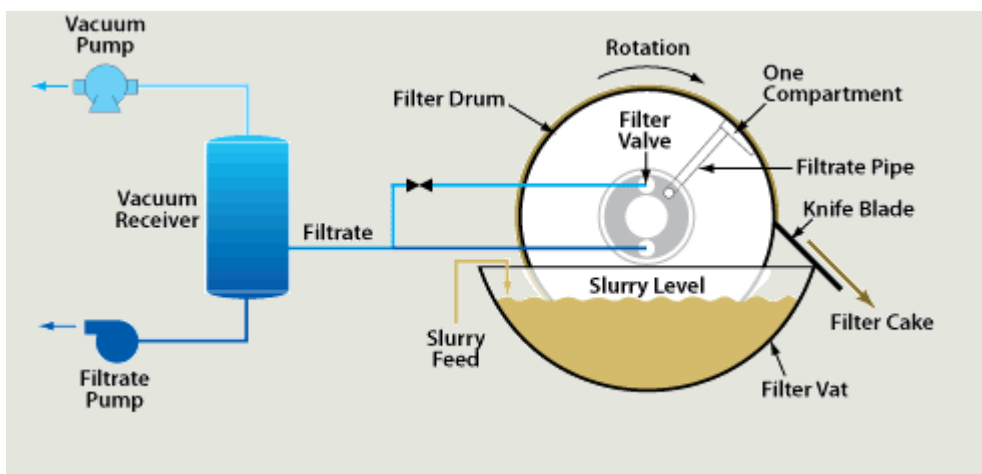
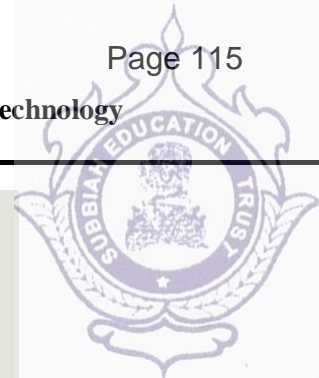

Figure:- Diagram depicting rotary drum vacuum filter operation and process flow

Vacuum pump is a small but strong pump of 5 to 10 HP. Water is extracted by vacuum and stored in the water separator. The mats are placed over fine filter pads, which prevent the removal of cement with water. Proper control on the magnitude of the water removed is equal to the contraction in total volume of concrete. About 3% reduction in concrete layer depth takes place. Filtering pad consists of rigid backing sheet, expanded metal, wire gauze or muslin cloth sheet.

3. Filter Presses

This equipment uses a filter medium to separate solids from the liquids. A filter press captures the solids in the pores between two or more porous plates. The solids captured are then pushed into the cavities by forcing water over them either through plate pressure or by build-up solid pressure.

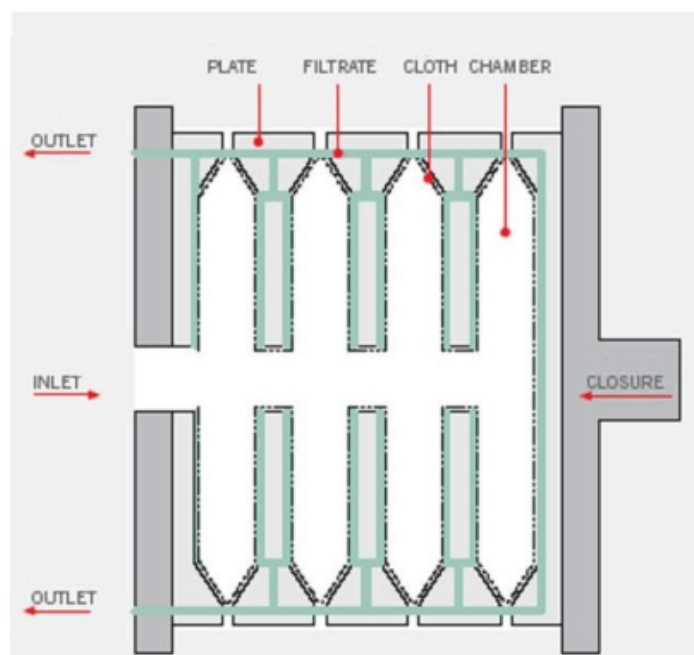
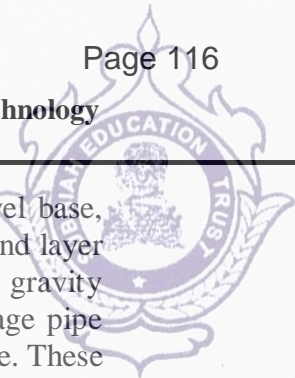

Figure:- Diagram depicting the layout of a filter press, including sludge flow and components

4. Drying Beds



It consists of a perforated or open joint drainage pipe placed within a layer of gravel base, which is again covered with a layer of sand. The sludge collected is placed over this sand layer and allowed to dry. The water from the sludge is removed by evaporation and by gravity movement to the underlying gravel base. This water is taken out through the drainage pipe placed in the gravel base. With time, the sludge dries, and cracks develop on the surface. These cracks allow the evaporation of lower layers of the sludge.

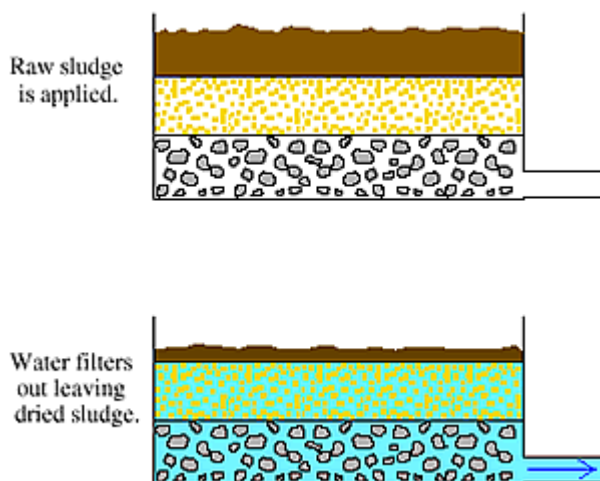

Figure-: Diagram depicting operation of a drying bed

The design parameters of a drying bed include:

- i. Depth of sludge
- ii. Moisture content of sludge
- iii. Availability of sand bed area

5. Sludge Lagoons

Sludge lagoons are excavated areas that are used to deposit and dry the sludge for several months to years. The depth of a sludge lagoon can vary from 2-6 feet.

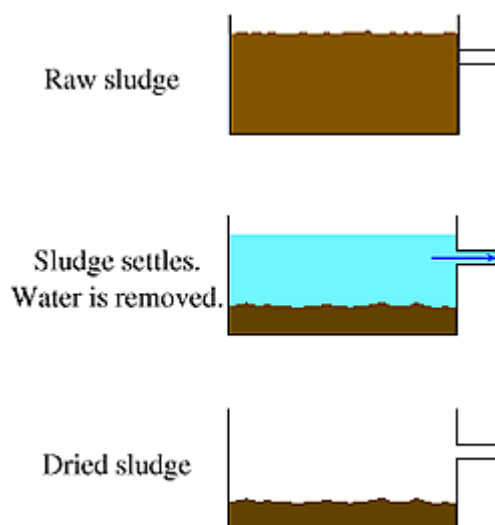
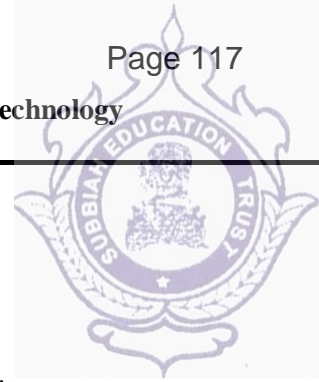

Figure-: Diagram depicting operation of a lagoon



Dewatering Equipment Selection Considerations

The selection of the most effective dewatering equipment for construction activities is dependent on:

- * Drying requirements
- * Cost
- * Sludge characteristics
- * Available area

The drying requirements and cost constraints are the primary factors governing the selection of the dewatering equipment. An engineer or industrial buyer must be aware of the sludge characteristics or corrosion potential of the water to be dewatered. The solids separated may possess hazardous contaminants or undesirable composition that may affect the performance of the equipment. For highly reactive sludge, the dewatering equipment like filter presses or gravity/low-pressure devices demand chemical conditioning prior to dewatering.

DUMP TRUCKS

A dump truck is a vehicle that is utilized at construction sites to transport construction materials to and from the site. Old types of trucks were dumped manually, and presently new types of dump trucks are accessible which can undoubtedly perform the tasks.

Dump trucks are a significant part of our mechanized, modern life. From hauling massive quantities of material to and from construction sites, street buildings, food transport, and mining.

Dump trucks arrive in a scope of sizes and unload components, contingent upon the planned reason for the truck. Most dump trucks can travel on typical public streets, while others are excessively huge and must be utilized onsite.

Types of Dump Trucks

1. Standard Dump Truck
2. Super Dump Truck
3. Winter Weather Dump Truck
4. Transfer Dump Truck
5. Side Dump Truck
6. Haul Dump Truck
7. Semi-Truck Trailer End Dump Truck
8. Semi-Truck Trailer Bottom Dump Truck
9. Articulated Haul Dump Truck

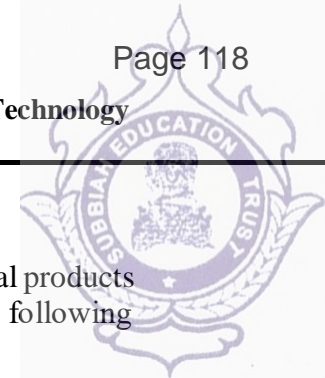

MATERIAL HANDLING AND ERECTION EQUIPMENTS

Material Handling equipment's are used in movement of bulk, packaged, & individual products within the limits of place of business. Material handling equipment's used for following purpose:

- To increase efficiency of material flow
- To reduce material handling cost
- To improve facilities utilization
- To improve safety & working conditions
- To facilitate construction processes
- To increase productivity

All Material handling equipment are classified in three main types, i.e

1. **CONVEYORS:** A conveyor system is a common piece of mechanical handling equipment that moves materials from one location to another in fixed path. Conveyors are especially useful in applications involving the transportation of heavy or bulky materials. Conveyor systems allow quick and efficient transportation for a wide variety of materials, which make them very popular in the material handling and packaging industries

Advantage

- Permits high capacity for moving large number of items
- Their speed is adjustable
- Handling combined with other activities such as processing & inspection is possible
- They are versatile & can be on floor or overhead
- Temporary storage of loads b/w work station is possible (particularly overhead conveyors)
- Load transfer is automatic & does not require the assistance of many operators
- Straight line paths or aisles are not required
- Utilization of the cube is feasible through the use of overhead conveyors



2. **CRANE & HOISTS:** Cranes & Hoists is a tower or derrick that is equipped with cables and pulleys that are used to lift and lower material. They are commonly used in the construction industry. Cranes for construction are normally temporary structures, either fixed to the ground or mounted on a custom-built vehicle or ship.

They can either be controlled from an operator in a cab that travels along with the crane, by a push button pendant control station, or by radio type controls.

Advantages:

- Lifting as well as transferring of material is possible
- Interference with the work on the floor is minimized
- Valuable floor space is saved for truck rather than being utilized for installation of handling equipment
- Such equipment is capable of handling heavy loads
- Such equipment can be used for loading & unloading of materials

The different types of cranes used in construction are:

Crawler Crane:

Crawler crane moves on tracks which is also called crawlers. Their main advantage is that it can move mostly on any surface of the earth it can even move on soft soils due to its crawlers as it transfers its load to a great area. That's why it can be used at unprepared sites without worrying about anything.



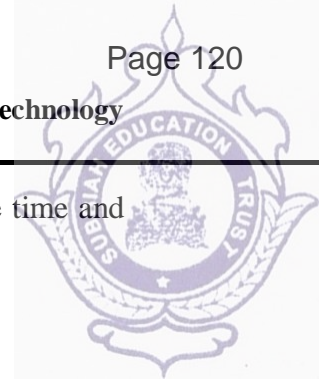

And it is very heavy and move on tracks hence mobility is not easy and take more time and will cost more money.

But it can be moved by trucks easily and without costing much money.

Rough Terrain Crane:

Rough Terrain Cranes are mounted on the four rubber tires. They are mostly used in off road applications. Outriggers are used for stabilizing the crane while working. They contain only one engine which means that same engine is used for undercarriage and crane.



A normal vehicle mounted crane cannot be used in off road constructions. That's why rough terrain cranes are used.

All Terrain Crane:

It is in those types of cranes which can travel at the same speed on the public roads as well as on the off roads. They also consist of more tires than rough terrain cranes.



The main difference between rough and all terrain cranes is that. Rough terrain usually travels on off roads not on public roads, while the all-terrain can be used in of both applications.

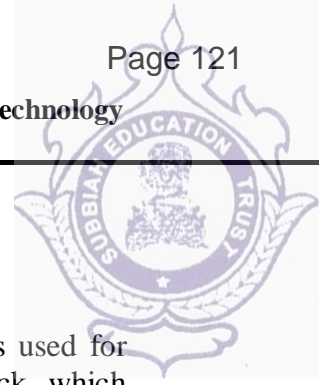

Truck Mounted Crane:

It is in that types of cranes which have one engine. It means that same engine is used for undercarriage and as well as for crane. They are mounted on a rubber tires truck, which provides great mobility. Outriggers are used to stabilize the truck by extending it horizontally or vertically.



Its main advantage is that it can travel on highways itself, which makes it easy and less expensive. It does not need any other vehicles to transport it.

They can be rotated up to 180 degrees. But some of them rotate up to 360 degrees but these are more expensive.

Telescopic Handler Cranes:



They contain a telescoping extend-able boom like crane. Their main purpose is to handle Bricks pallet and install frame trusses in buildings. They are designed too simple to improve

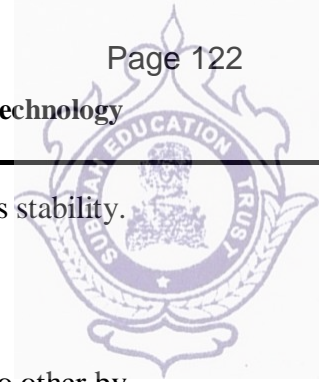

workability. They can rotate up to 360 degrees and also have outriggers to maintain its stability. They look like forklift trucks.

Pick and Carry Crane:

These types of cranes are the mostly used for shifting of small load from one place to other by lifting of material. These cranes are most widely used for carrying and shifting of material.



Tower Cranes:

These types of cranes are the mostly used cranes in today's world. Usually, they are fixed to the ground in concrete or attached to the side of structures. They are used mostly in the construction of tall buildings.



They can lift load up to 30 tons approximately. The operators of the crane mostly use radio and hand signals as a medium for communication to hook or unhook the load.

Overhead / Gantry Crane

Also referred to as a suspended crane, this type is normally used in a factory, with some of them being able to lift very heavy loads. Larger overhead cranes (also known as goliath cranes) can be found in use in shipyards and large outdoor manufacturing plants. The hoist is set on a trolley which will move in one direction along one or two beams, which move at angles to that

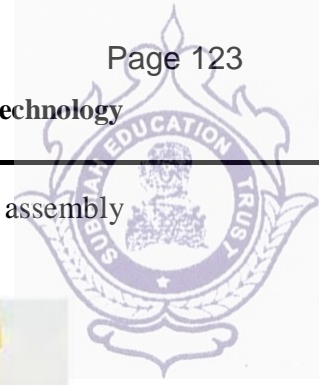

direction along elevated or ground level tracks, often mounted along the side of an assembly area.



Rail Road Cranes:



These types of cranes move on the railway track. Rail Road Cranes are used for the construction of railway lines, maintenance and for their repairing. They cannot travel on roads or any other place except railway tracks due to its flanged wheels.

Floating Crane:



It is also called crane ship, crane vessel or floating crane. It is mostly used in offshore construction and they are specialized in the lifting of heavy loads. They can also be used to load or unload ships or lift sunken ships from the water. They are fixed and therefore cannot be rotated. They have a large capacity of about 9000 tons.

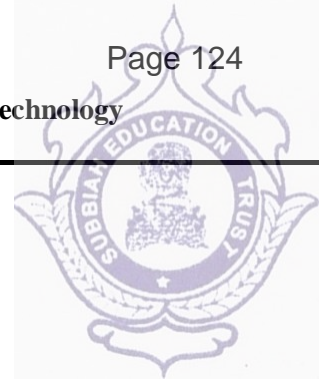

Harbour Crane:



It is also called mobile harbour or port harbour crane. It is mostly used in sea ports to unload or load the ships. The flexibility of the machine makes it easy to use it at any place. Its main advantage is, that it is among the powerful material handling cranes. This means that materials will be transported from one place to another safely and with ease.

Aerial Cranes:



These types of cranes are also called Sky Cranes. They look like helicopters and used to carry large loads. They are used mostly in that place where reaching by land is difficult.

They usually lift loads to high rise buildings. They can also be used for rescue purposes in disaster.

Pipe Layer: Pipe Layer is used for laying of pipe in difficult terrain.

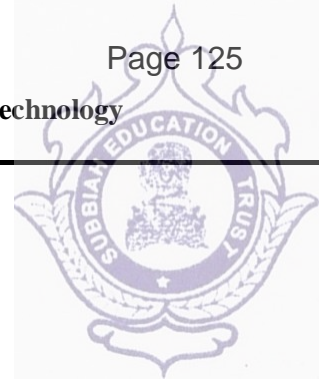

Tower Hoist: Tower Hoist is popularly known as Builders Hoist & is used mostly for carrying up concrete.

Various models available depending upon weight to be carried and height it is to be carried. It is used mostly for carrying up concrete, and also brick, tiles, steel by exchange of bucket.



Passenger Hoist: Passenger Hoist, commonly known as outdoor elevators, provide safe and speedy vertical transport of personnel and materials.



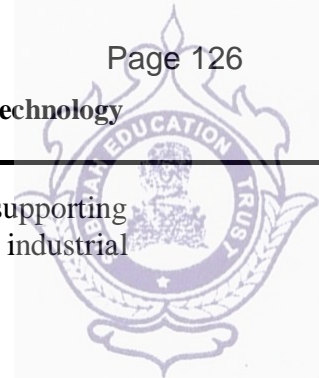

Jib Crane: A jib crane is a type of crane where a horizontal member (jib or boom), supporting a moveable hoist, is fixed to a wall or to a floor-mounted pillar. Jib cranes are used in industrial premises and on military vehicles.



The jib may swing through an arc, to give additional lateral movement, or be fixed. Similar cranes, often known simply as hoists, were fitted on the top floor of warehouse buildings to enable goods to be lifted to all floors.

Suspended Platform:



Suspended Platform is light weight steel make object is capable of caring personnel for carry out of aerial work.

3. **TRUCKS:** Hand or Powered Trucks move loads over varying paths Examples of such Trucks include Lift Trucks, Fork Trucks, Trailer Trains, & Automated Guided Vehicles

Advantages:

- They are not requiring to follow a fixed path of movement & therefore can be used anywhere on the floor where space permits
- They are capable of loading, unloading, & lifting, in addition to transferring material
- Because of their unrestricted mobility, which allows them to serve different areas, trucks can achieve high utilization

(a) Forklift Trucks

Forklift trucks are used for horizontal and limited vertical transportation of packaged materials positioned on pallets or banded together such as brick packs.

They are generally suitable for construction sites where the building height does not exceed three stories. Although designed to negotiate rough terrain sites, forklift trucks have a higher productivity on firm and level soils.

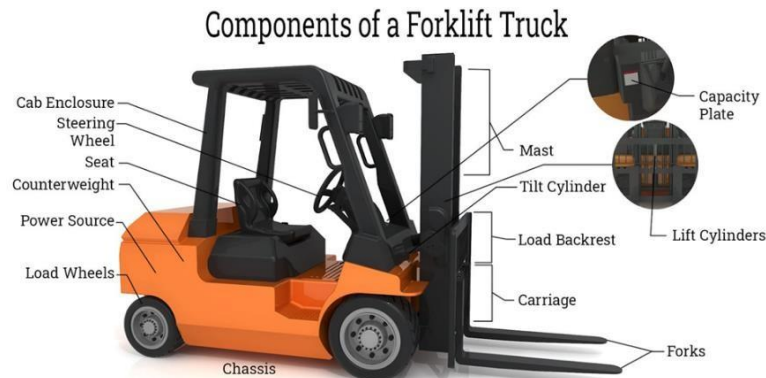

UNIT-V

CONSTRUCTION PLANNING

Planning, scheduling is an important part of the construction management. Planning and scheduling of construction activities helps engineers to complete the project in time and within the budget. The term 'Construction' does not only denote physical activities involving men, materials and machinery but also covers the entire gamut of activities from conception to realization of a construction project. Thus, management of resources such as men, materials, machinery requires effective planning and scheduling of each activity.

Construction Management

Management is the science and art of planning, organizing, leading and controlling the work of organization members and of using all available organization resources to reach stated organizational goals. Construction management deals with economical consumption of the resources available in the least possible time for successful completion of construction project. 'Men', 'materials', 'machinery' and 'money' are termed as resources in construction Management.

Objectives of Construction Management:

The main objectives of construction management are,

- Completing the work within estimated budget and specified time.
- Maintaining a reputation for high quality workmanship

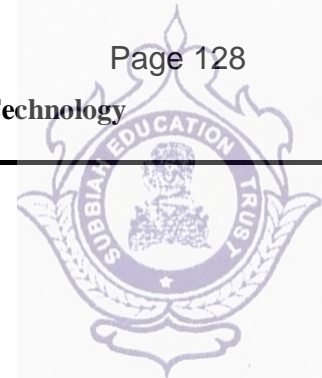

- Taking sound decisions and delegation of authority
- Developing an organization that works as a team.

Importance of construction project planning:

- Planning helps to minimize the cost by optimum utilization of available resources.
- Planning reduces irrational approaches, duplication of works and inter departmental conflicts.
- Planning encourages innovation and creativity among the construction managers.
- Planning imparts competitive strength to the enterprise.

Importance of construction project scheduling:

- Scheduling of the programming, planning and construction process is a vital tool in both the daily management and reporting of the project progress.

Functions of Construction Management:

The functions of construction Management are (a) Planning (b) Scheduling (c) Organizing (d) Staffing (e) Directing (f) Controlling (g) Coordinating

(a) Planning in Construction Management:

It is the process of selecting a particular method and the order of work to be adopted for a project from all the possible ways and sequences in which it could be done. It essentially covers the aspects of 'What to do' and 'How to do it'.

The Critical Path

The critical path describes the sequence of tasks that would enable the project to be completed in the shortest possible time. It is based on the idea that some tasks must be completed before others can begin. A critical path diagram is a useful tool for scheduling dependencies and controlling a project. In order to identify the critical path, the length of time that each task will take must be calculated.

Let's take a look at an example. The length of time in weeks for each key stage is estimated:

Table 1 Stages of the Critical Path

Key stage	Estimated time in weeks
A. Secure funds	0

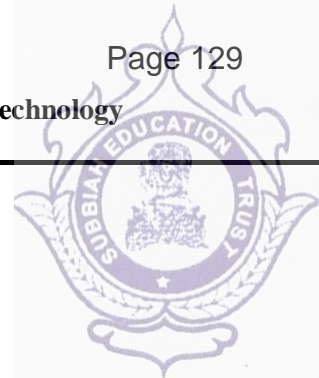

B. Negotiate with other agencies	4
C. Form advisory group	4
D. Establish data collection plan	6
E. Collect data	4
F. Write directory text	4
G. Identify printer	2
H. Agree print contract	2
I. Print directory	4
J. Agree distribution plan	12
K. Organize distribution	4
L. Distribute directory	2

We have given the key stage “Secure funds” an estimated time of zero weeks because the project cannot start without the availability of some funding, although estimates would provide detail at a later stage. The stages can now be lined up to produce a network diagram that shows that there are three paths from start to finish and that the lines making up each path have a minimum duration (Figure 1).

If we now trace each of the possible paths to “Distribute directory” (the finishing point), taking dependencies into account, the route that has the longest duration is known as the critical path. This is the minimum time in which it will be possible to complete the project.

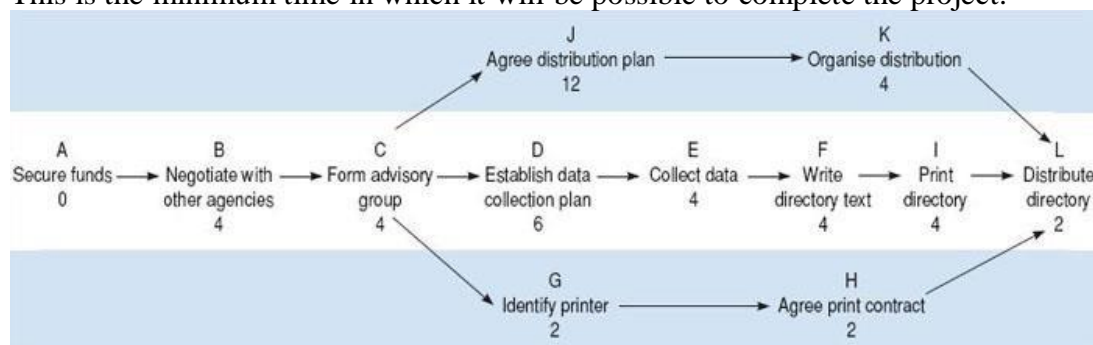
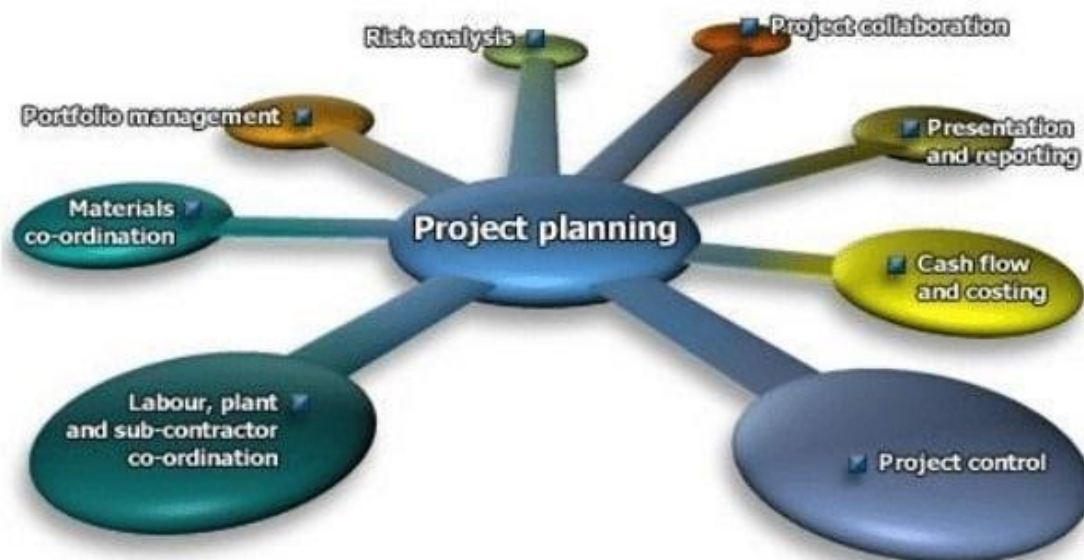

Figure 2: Critical Path Diagram

In this example, the critical path is A–B–C–D–E–F–I–L, and the earliest completion date for the project is the sum of the estimated times for all the stages on the critical path – 28 weeks – from the point of securing the funding. All the key stages on the critical path must be completed on time if the project is to be finished on schedule.

If the projected total time is much longer than the project sponsor's expectations, you will need to renegotiate the time scale. Mapping the critical path helps to identify the activities that need to be monitored most closely.



b) Scheduling in Construction Management:

Scheduling is the fitting of the final work plan to a time scale. It shows the duration and order of various construction activities. It deals with the aspect of 'when to do it'.

c) Organizing: Organizing is concerned with decision of the total construction work into manageable departments/sections and systematically managing various operations by delegating specific tasks to individuals.

d) Staffing: Staffing is the provision of right people to each section / department created for successful completion of a construction project.

e) Directing: It is concerned with training sub ordinates to carryout assigned tasks, supervising their work and guiding their efforts. It also involves motivating staff to achieve desired results.

f) Controlling: It involves a constant review of the work plan to check on actual achievements and to discover and rectify deviation through appropriate corrective measures.

g) Coordinating: It involves bringing together and coordinating the work of various departments and sections so as to have good communication. It is necessary for each section to aware of its role and the assistance to be expected from others.

Importance of Construction Management:

- Construction management practices invariably lead to "maximum production at least cost". A good construction management, results in completion of a construction

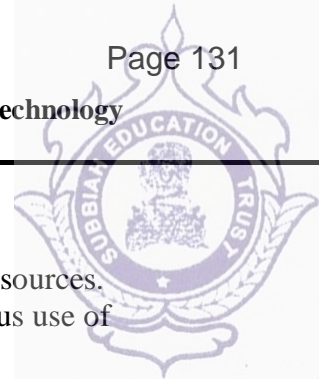

project within the stipulated budget.

- Construction management provides importance for optimum utilization of resources. In other words, it results in completion of a construction project with judicious use of available resources.
- Construction management provides necessary leadership, motivates employees to complete the difficult tasks well in time and extracts potential talents of its employees.
- Construction management is beneficial to society as the effective and efficient management of construction projects will avoid, escalation of costs, time overrun, wastage of resources, unlawful exploitation of labor and pollution of environment.

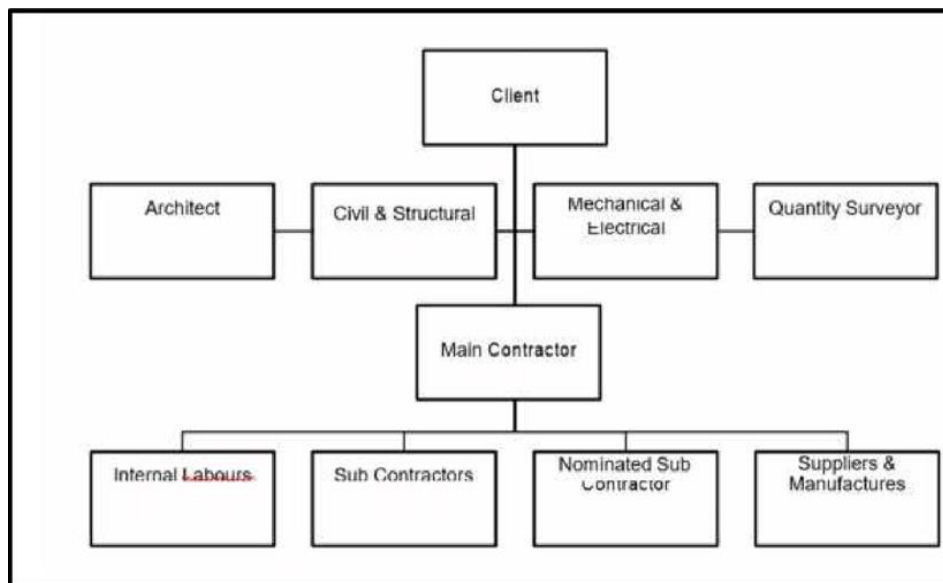

Benefits of PERT/CPM

- * Useful at many stages of project management
- * Mathematically simple
- * Give critical path and slack time
- * Provide project documentation
- * Useful in monitoring costs

Limitations of PERT/CPM

- * Clearly defined, independent and stable activities
- * Specified precedence relationships
- * Over emphasis on critical paths

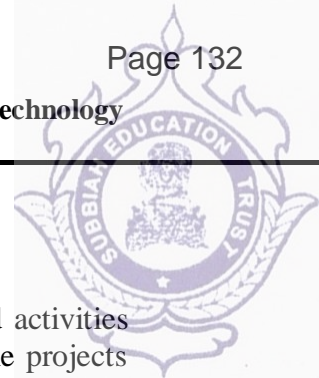

CPM AND PERT NETWORK MODELLING AND TIME ANALYSIS

Any project involves planning, scheduling and controlling a number of interrelated activities with use of limited resources like, men, machines, materials, money and time. The projects may be extremely large and complex such as construction of a power plant, a highway, a shopping complex, ships and aircraft. It is required that managers must have a dynamic planning and scheduling system to produce the best possible results and also to react immediately to the changing conditions and make necessary changes in the plan and schedule. A convenient analytical and visual technique of PERT and CPM prove extremely valuable in assisting the managers in managing the projects. PERT and CPM are basically time-oriented methods in the sense that they both lead to determination of a time schedule for the project. The significant difference between two approaches is that CPM is an activity-oriented network while PERT is event oriented. CPM has single time estimate which is assumed to be deterministic and PERT has three time estimates for activities and uses probability theory to find the chance of reaching the scheduled time.

NETWORK DIAGRAM REPRESENTATION

In a network representation of a project the following representations are used:

Activity: Any individual operation which utilizes resources and has an end and a beginning is called activity. An arrow is commonly used to represent an activity with its head indicating the direction of progress in the project.

Here 'A' is the activity. These are classified into four categories:

(i) **Predecessor activity** - Activities that must be completed immediately prior to the start of another activity are called predecessor activities.

(ii) **Successor activity** - Activities that cannot be started until one or more of other activities are completed but immediately succeed them are called successor activities.

(iii) **Concurrent activity** - Activities which can be accomplished concurrently are known as concurrent activities. It may be noted that an activity can be a predecessor or a successor to an event or it may be concurrent with one or more of other activities.

(iv) **Dummy activity** An activity which does not consume any kind of resource and time is called a dummy activity. Dummy activities are simply used to represent a connection between events in order to maintain logic in the network. It is represented by a dotted line in a network.

